

# MECHON



Department of Mechanical Engineering



# Message from Dean

I am proud to announce the release of 'MECHON' magazine's first issue. The magazine signifies the writer's penmanship and also allows them to share their ideas. I acknowledge the efforts of students and staff of Mechanical department who have taken the initiative to promote the writing and publishing skills of the students. This helps the students to share and express their ideas in an articulate manner.

Students and staff achievements have also been presented which will be a motivational factor for the other students to achieve the standard of excellence. Glad to say that we have achieved our aim of turning this into reality. I would like to congratulate all the students, teachers, alumni and everyone involved in bringing out its 1st edition.

Wishing everyone loads of success and bright future.

Dr. R. R. Sedamkar





## **Message by Mentor Dean**

It is a great pleasure and I feel honoured to be a part of the first e-magazine of Department of Mechanical Engineering. This is one of the youngest departments of Thakur College of Engineering and Technology. Its first batch passed out in 2016. Students have shown tremendous potential not only in academics but also in co-curricular and extra curricular activities.

At the International conference faculties and students published technical paper in International journals. Some of the papers were also published in Tata McGraw Hill Publication. Second year and third year students were also encouraged to present the paper in different domains of Mechanical Engineering.

Students are showing commendable performance in GRE, CET-MBA and GATE examinations, which can be compared with any other institution in India.

For overall personality development apart from academic, co-curricular and extra curricular is the need of the hour. Students are encouraged to participate in inter and intra-college competition. All these activities help them in getting jobs in reputed companies. They are also admitted in institution of high repute for higher studies in India and abroad.

I congratulate all faculties, students and staff for their hard work in publishing e-magazine that will represent the insight of Mechanical department.

Wishing them best of luck!

Dr. Sanjay Kumar





## **Message by Head of Department**

I am pleased to know that our students are successful in bringing their first issue of magazine MECHON for this academic year 2017-18. MECHON, the departmental magazine has the prime objective of providing aspiring engineers a wide platform to showcase their technical knowledge and to pen down innovative ideas.

This magazine is intended to bring out the hidden literary talents in the students and teachers to inculcate strong technical skills among them. I congratulate and thank all the students and faculty coordinator who have made untiring efforts to bring out this magazine. I wish them all the very best for releasing more such magazines in future.

Dr. Siddesh Siddapa





# Message from Faculty In-charge

It gives me immense pleasure to present the very first issue of “MECHON” magazine of the Department of Mechanical Engineering. It is the talent and outcome of our students which is reflected through this. This is one of the best platforms for our students to present multifaceted personalities and innovative ideas.

I take this opportunity to thank our respected Principal Dr. B. K. Mishra, Dean Academics Dr. R. R. Sedamkar, Dean Mentor Dr. Sanjay Kumar, HOD Dr. Siddesh Siddappa and all the faculty members for their incessant inspiration and kind support.

I believe that this edition, will prove to be a success. I express my heartfelt gratitude to the editorial committee for their relentless efforts, the young writers for their valuable articles and all those who have been a part of “MECHON”.

Mr. Pawan Tiwari



# FACULTY



Department of Mechanical Engineering



# TEAM

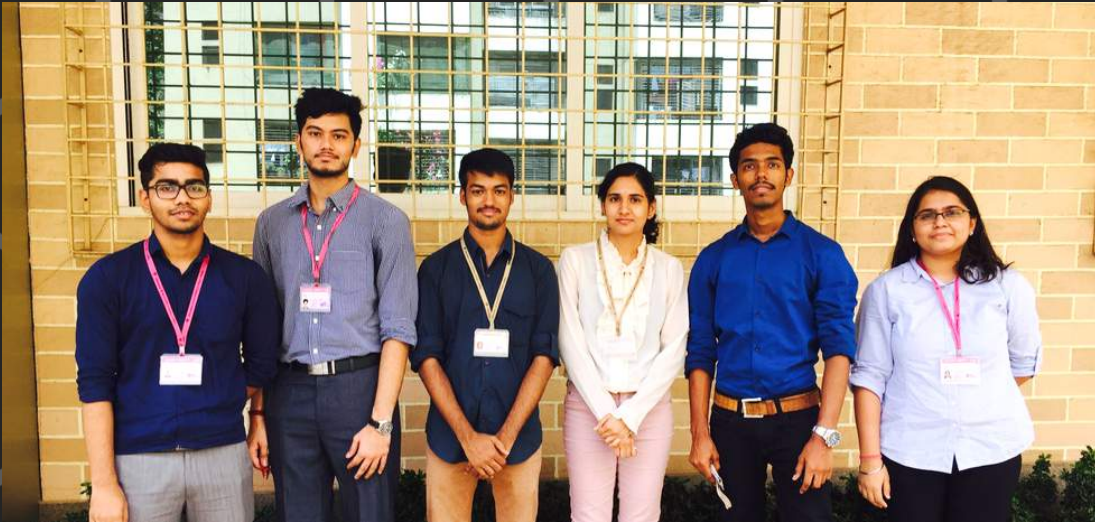

(Sudhir -Aditya - Vishal - Neha - Saurabh - Snehal)

**SAURABH VAIDYA**

Editor

**VISHAL GUPTA**

Editor (Design)

**NEHA NEWASKAR**

Editor (Content)

**ADITYA TANTRI**

Designer

**SUDHIR YADAV**

Designer

**SNEHAL TIWARI**

Content Writer

# FACULTY ARTICLES

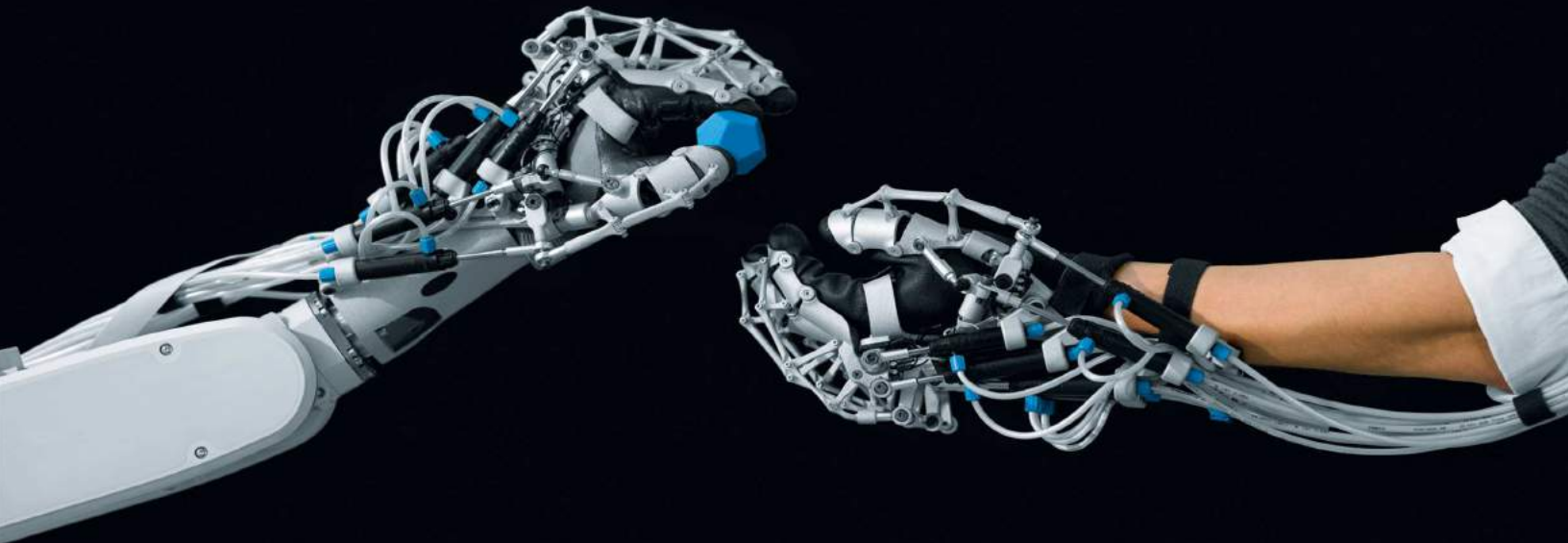



# Waste Heat Recovery from Domestic Refrigerator

by Mr. Iqbal Mujawar

## I. INTRODUCTION:

Waste heat is heat, which is generated in a process by way of fuel combustion or chemical reaction, heat removed from thermal system by heat exchanger and then “dumped” into the environment even though it could still be reused for some useful and economic purpose. The essential quality of heat is not the amount but rather its “value”. The strategy of how to recover this heat depends in part on the temperature of the waste heat gases and the economics involved.



Use of waste heat recovery is an important technique of reducing total energy costs in energy system design. Attachments need to be developed to recover waste heat energy from air conditioning or refrigeration systems. If the heat recovery system is designed optimally and implemented in residential and small-scale commercial systems, the cumulative benefits would be significant

Households need both refrigeration and water heating. Refrigeration at temperatures below 4°C is employed for food preservation, while hot water at temperatures around 55°C is used for bathing and showering. But it is common for refrigeration and water heating to be separated and unconnected, each consuming their own purchased energy.

A more efficient use of this electrical energy would be to integrate the refrigeration and hot water systems. This would reduce the electrical power consumed by heating water, by making use of the heat rejected by refrigerators.

A home's single largest electricity expense is water heating, which typically accounts for about 40% of their electricity usage. The total energy consumption by geysers will continue to increase as the population grows. As electricity demand increases, the adverse environmental effects and the economic costs associated with electricity generation will also increase.







The vapour compression refrigeration cycle is a common method for transferring heat from a low temperature to a high temperature.

The figure shows the objectives of refrigerators and heat pumps. The purpose of a refrigerator is the removal of heat, called the cooling load, from a low-temperature medium. The purpose of a heat pump is the transfer of heat to a high-temperature medium, called the heating load. When we are interested in the heat energy removed from a low-temperature space, the device is called a refrigerator. When we are interested in the heat energy supplied to the high-temperature space, the device is called a heat pump.

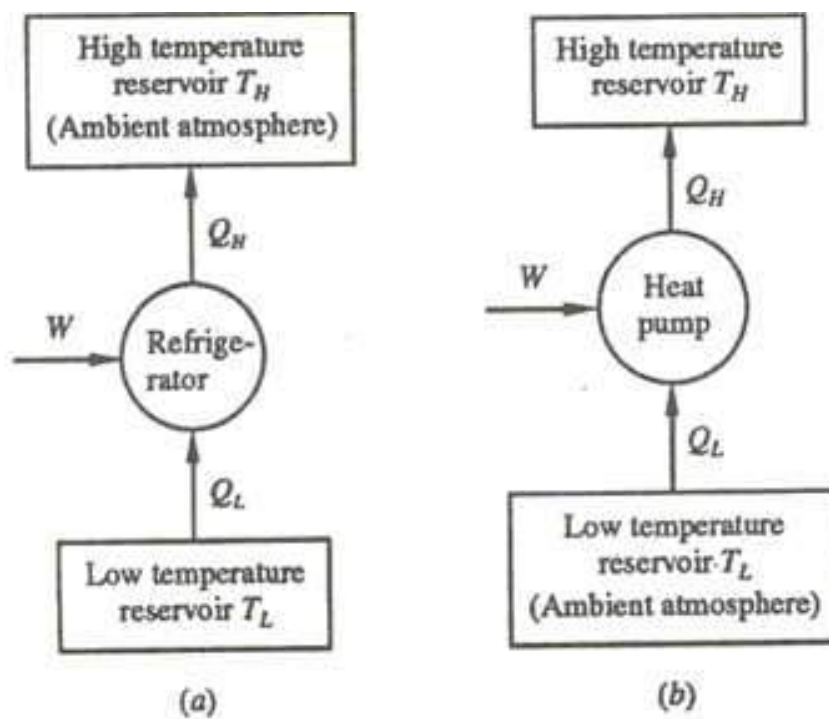

In general, the term heat pump is used to describe the cycle as heat energy is removed from the low-temperature space and rejected to the high-temperature space.

Both refrigerators and heat pumps move heat from a cold thermal reservoir to a warm thermal reservoir. The objective of refrigerators is to remove heat from a cold space whereas the objective of heat pumps is to put heat into a warm space. Both heat pumps and refrigerators use the same thermodynamic cycle and principles.

When a household refrigerator is operating, it rejects heat into the environment at the condenser and in warm climates that heat is usually wasted. In this paper, the feasibility of a new system which used the rejected heat at the condenser of the refrigerator to heat water in the geyser was investigated. Thus, a combined refrigerator/heat exchanger and geyser resulted in a single machine which maintained a certain physical space at cold temperature for storage of food and used the heat rejected by the refrigeration part for water heating.



The figure shows that a vapour compression cycle was used with the evaporator in the refrigerator and condenser in the heat exchanger which was connected to the geyser. Cold and low pressure refrigerant gas entered the compressor where its pressure (and temperature) increased. After the compressor, it then passed through the condenser where it gave up heat at approximately constant pressure to the water in the geyser so that the refrigerant's temperature decreased sufficiently for it to condense into a sub cooled liquid.

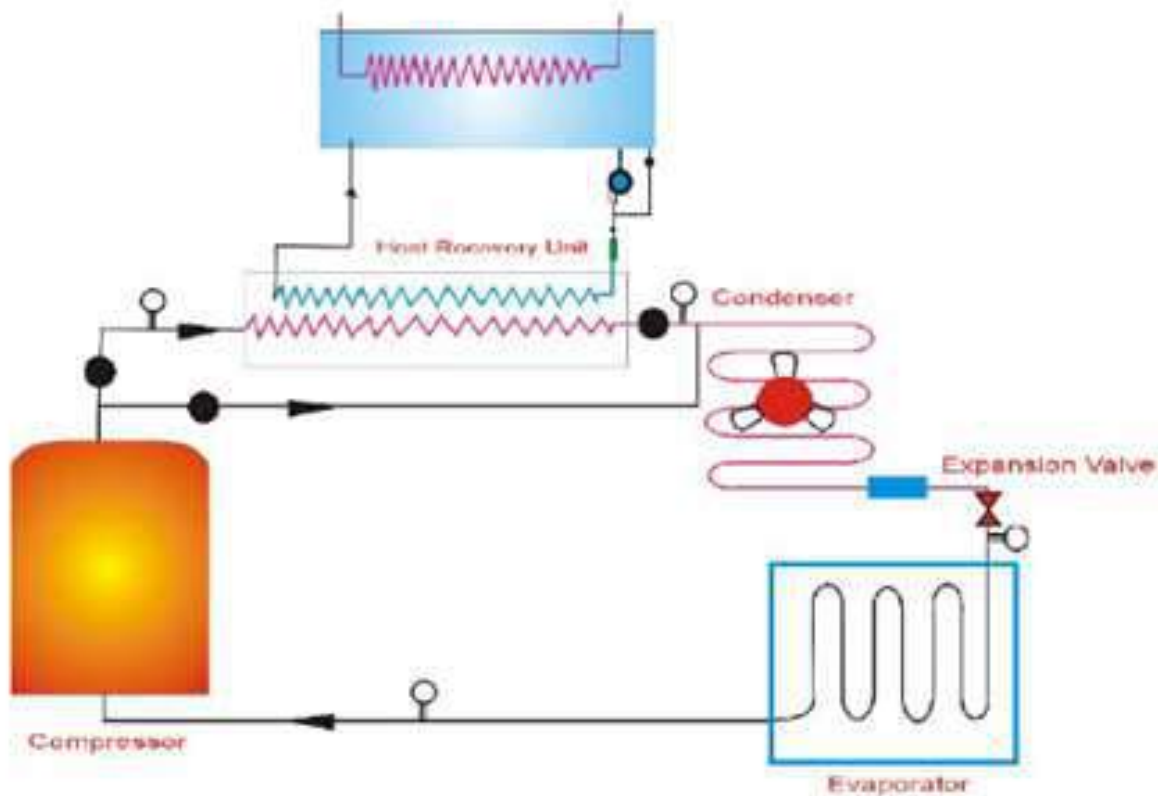

A combined vapor-compression refrigeration system and geyser

After leaving the condenser it went through an expansion valve (which may be a capillary tube). The decrease in pressure in the expansion process caused the refrigerant to turn back into a mixture of liquid and vapour but at a much lower temperature. Then it went to the evaporator where it absorbed heat at approximately constant pressure from the food in the refrigerator.

## II. LITERATURE REVIEW

Clark et al.1996, describe the design, construction, and testing of an integrated heat recovery system which has been designed both to enhance the performance of a residential refrigerator and simultaneously to provide preheated water for an electric hot water heater. A commercial, indirect-heated hot water tank was retrofitted with suitable tubing to permit it to serve as water cooled condenser for a residential refrigerator. This condenser operates in parallel with the air-cooled condenser tubing of the refrigerator so that either one or the other is active when the refrigerator is running. The refrigerator was housed in a controlled-environment chamber, and it was instrumented so that its performance could be monitored carefully in conjunction with the water pre-heating system.





The system has been tested under a variety of hot water usage protocols, and the resulting data set has provided significant insight into issues associated with commercial implementation of the concept. For the case of no water usage, the system was able to provide a 35 °C temperature rise in the storage tank after about 100 hours of continuous operation, with no detectable deterioration of the refrigerator performance. Preliminary tests with simulations of “high water usage,” “low water usage,” and “family water usage” indicate a possible 18-20% energy savings for hot water over a long period of operation. Although the economic viability for such a system in a residential environment would appear to be sub-marginal, the potential for such a system associated with commercial-scale refrigeration clearly warrants further study, particularly for climates for which air conditioning heat rejection is highly seasonal

Stinson et al.1987, conducted research in dairy refrigeration by recovering the heat from condenser. A theoretical energy balance was conducted, from which the potential for recovery of refrigeration condenser heat was estimated to be up to 60% of the water heating energy requirements. Preliminary tests with heat exchangers led to the development and testing of a tube-in-tube, counter flow heat exchanger, with fins on the refrigerant side and cores on the water side to improve the heat transfer characteristics. The exchanger, designed to provide 300 l of water at 60°C from a 2.25 kW refrigeration system which cooled 2100 l of milk per day, had a surface area on the refrigerant side of 0.84, and an overall thermal conductance of 750 W m<sup>-2</sup> C<sup>-1</sup>.

It was inserted between the compressor and the condenser of the refrigeration plant and tested with two condensing systems (air and water), together with varying conditions of condenser pressure and milk temperatures at inlet and final cooling. In addition, tests on the receiver pressure and suction superheat were performed to determine their effect on the overall system performance. Increasing the condenser pressure from 6.5 bar to 12 bar increased cooling times. In extreme circumstances the system failed to comply with the New Zealand milk cooling regulations. The average coefficient of performance (C.O.P.) of the refrigerator (with the heat exchanger in the circuit) decreased with increasing pressure, varying from 3.0 to 2.3 over this range of pressures for the water cooled condenser system. Values for the air cooled condenser system were 0.3 to 0.4 lower due to fan power consumption.

Sanmati Mirji 2006, presented a multipurpose warming apparatus utilizing the waste heat of domestic refrigerator. The multipurpose apparatus was constructed as an additional part of the refrigerator. It used the waste heat generated by the refrigerator and has several possible household uses like food warming, domestic fermentation purposes such as curd making, fermentation for Indian food. The maximum temperature of the chamber got as high as 50°C and the average temperature was around 40 °C. The main advantage of the invention was to keep cooked food warm for a sufficiently long duration before consumption as well as warming the food removed from the refrigerator before consumption. It makes use of the waste heat generated by the domestic refrigerator and does not need any additional power supply.

Mills 1986, investigated several methods of heat recovery as applied to a residence. One of the more interesting approaches involved the reclamation of heat from water after it has been utilized. Waste water is collected in a 454 litre holding tank, which also contains the evaporator for a 1.2 kW water-to-water heat pump. When the water temperature in the holding tank rises above a certain point, the heat pump is activated, transferring heat from the holding tank to the condenser which is mounted inside a 272 litre fresh hot water storage tank. An experimental prototype of this system was constructed and tested using a water usage pattern that was derived from an accepted standard hot water delivery schedule. The tests indicated that an energy savings of up to 60% over a typical 272 litre electric hot water heater was possible.

# Signature Analysis as a Tool for Vibration Measurement

by Mrs. Rajeshwari Jaisinghani

## INTRODUCTION:

The ability to plan and execute a repair schedule is extremely important in capital intensive industries. Unscheduled downtime is a bit like experiencing a major disaster 'all hell breaks loose'. Therefore the condition monitoring is important to detecting the fault in industrial machines. Condition monitoring is the measurement of various parameters related to the mechanical condition of the machinery, which makes it possible to determine whether the machinery is in good or bad mechanical condition. If the mechanical condition is bad, then condition monitoring makes it possible to determine the cause of the problem. Condition monitoring is used in conjunction with predictive maintenance, i.e., maintenance of machinery based on an indication that a problem is about to occur. In many plants predictive maintenance is replacing run-to-breakdown maintenance and preventive maintenance (in which mechanical parts are replaced periodically at fixed time intervals regardless of the machinery's mechanical condition).

## TYPES OF CONDITION MONITORING SYSTEMS:

Condition monitoring systems are of two types: periodic and permanent. In a periodic monitoring system also called an off-line condition monitoring system, machinery vibration is measured or recorded and later analysed at selected time intervals in the field; then an analysis is made either in the field or in the laboratory. Advanced analysis techniques usually are required for fault diagnosis and trend analysis. Intermittent monitoring provides information at a very early stage about incipient failure and usually is used where (1) very early warning of faults is required, (2) advanced diagnostics are required,

(3) measurements must be made at many locations on a machine, and (4) machines are complex. In a permanent monitoring system also called an on-line condition monitoring system, machinery vibration is measured continuously at selected points of the machine and is constantly compared with acceptable levels of vibration. The principal function of a permanent condition monitoring system is to protect one or more machines by providing a warning that the machine is operating improperly and/or to shut the machine down when a preset safety limit is exceeded, thereby avoiding catastrophic failure and destruction. The measurement system may be permanent (as in parallel acquisition systems where one transducer and one measurement chain are used for each measurement point), or it may be quasi-permanent (as in multiplexed systems where one transducer is used for each measurement point but the rest of the measurement chain is shared between a few points with a multiplexing interval of a few seconds). In a permanent monitoring system, transducers are mounted permanently at each selected measurement point. For this reason, such a system can be very costly, so it is usually used only in critical applications where: (1) no personnel are available to perform measurements such as offshore, remote pumping stations, etc., (2) it is necessary to stop the machine before a breakdown occurs in order to avoid a catastrophic accident, (3) an instantaneous fault may occur that requires machine shutdown, and (4) explosive, toxic, or high-temperature environment does not permit the human involvement required by intermittent measurements. Before a permanent monitoring system is selected, preliminary measurements should be made periodically over a period of time to become acquainted with the vibration characteristics of the machine.



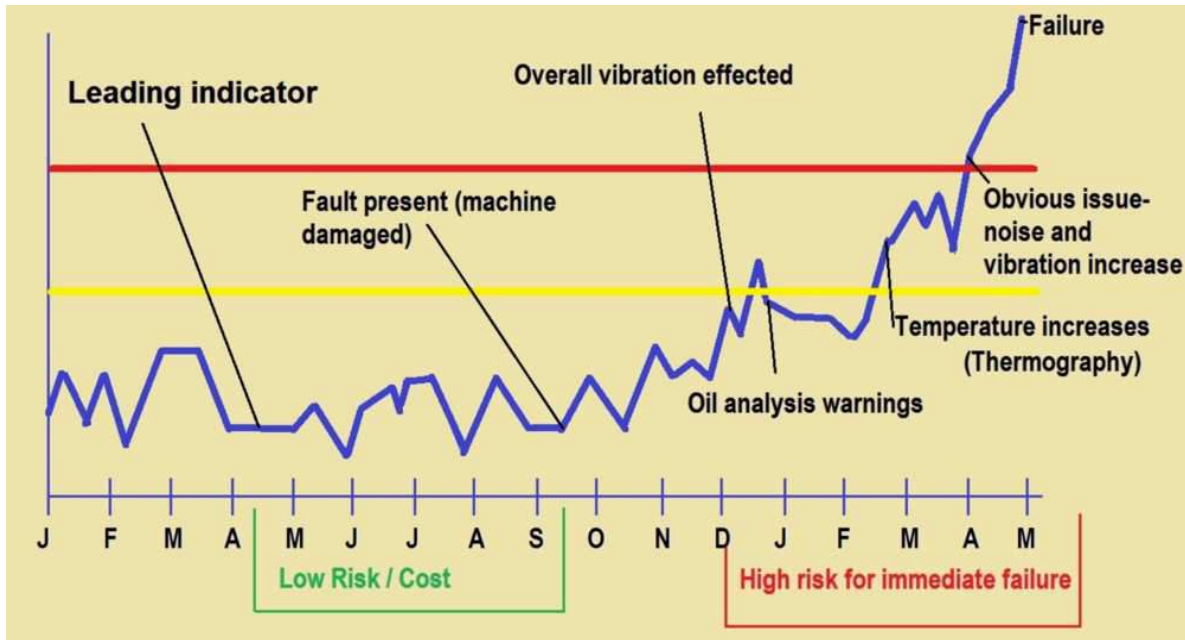

**SIGNATURE ANALYSIS:**

Fault detection of mechanical equipment based on vibration analysis consists in determine the relation between measured signals and fault model signals. Faults model signals are generated by simulation based on a-priori knowledge about mechanical dynamic behaviour of the process. If changes in these signals are related to faults in the mechanical equipment, a signature analysis procedure will be a further source of information. About machine vibration, sensors are used to detect for instance, imbalance and bearing faults. The extraction of fault-relevant signal characteristics can in many cases be restricted to the amplitudes or amplitude densities within a certain bandwidth of the signal. In order to acquire some knowledge about qualitative aspects of faults, more information can be extracted by comparing the spectrum of vibration frequencies with a pattern of the faulty process. Resulting coincidences between measured signals and signal model of faulty process or faulty pattern spectrum are considered as deterministic faults.

**VIBRATION SIGNATURE ANALYSIS:**

The word signature has been coined to designate signal patterns which characterize the state or condition of a system from which they are acquired. Signatures are extensively used as a diagnostic tool for mechanical system. In many cases, some kind of signal processing is undertaken on those signals in order to enhance or extract specific features of such vibration signatures. It is very important to consider the type and range of transducers used as pickup for capturing vibration signal. Signature-based diagnostic makes extensive use of signal processing techniques involving one or more methods to deal with the problem of improvement in the signal to noise ratio. Vibration-based monitoring techniques have been widely used for detection and diagnosis of bearing defects for several decades. These methods have traditionally been applied, separately in time and frequency domains. A time-domain analysis focuses principally on statistical characteristics of vibration signal such as peak level, standard deviation, skewness, kurtosis, and crest factor. A frequency domain approach uses Fourier methods to transform the time-domain signal to the frequency domain, where further analysis is carried out, and conventionally using vibration amplitude and power spectra.

## TOOLS FOR SIGNATURE ANALYSIS:

ISO – 10816

ISO 10816-1 is the basic document which describes the general requirements for evaluating the vibration of various machine types when the vibration measurements are made on non – rotating parts. This part of ISO 10816 provides specific guidance for assessing the severity of vibration measured on bearings, bearing pedestals or housing of industrial machines.

### MEASUREMENT QUANTITY

For the purposes of this part of ISO 10816, the following can be used:

- (a) Vibration displacement, measured in micrometres;
- (b) Vibration velocity, measured in millimetres per second;
- (c) Vibration acceleration, measured in metres per square second.

### VIBRATION MAGNITUDE

It is common practice, based on experience, when evaluating broad – band vibration of rotating machinery to consider the r.m.s value of vibration velocity, since this can be related to the vibration energy. However, other quantities such as displacement or acceleration and peak values instead of r.m.s values may be preferred. In this case, alternative criteria are required which are not necessarily simply related to criteria based on r.m.s values.

### MEASURING POSITIONS

To define the vibrational behaviour at each measuring position, it is necessary to take measurements at three mutually perpendicular directions. The requirement for operational monitoring is usually met by performing one or both measurements in the radial direction (i.e. normally in the horizontal transverse and / or vertical directions). These can be supplemented by a measurement of axial dynamic force are transmitted.

VIBRATION SEVERITY PER ISO 10816-1						
Machine		Class I	Class II	Class III	Class IV	
		Small Machines	Medium Machines	Large Rigid Foundation	Large Soft Foundation	
Vibration Velocity Vrms	in/s	mm/s				
	0.01	0.28				
	0.02	0.45				
	0.03	0.71				
	0.04	1.12				
	0.07	1.80				
	0.11	2.80				
	0.18	4.50				
	0.28	7.10				
	0.44	11.20				
	0.70	18.00				
	1.10	28.00				
1.77	45.90					





# Simulations

by Mr. Mahendra Shelar

## Automotive

The automotive industry has undergone profound changes in recent years. Cars need to be more fuel-efficient and environmentally friendly. Traditional combustion engines are being replaced by fuel cells, batteries, opposed-piston technologies or electric traction motors. Innovations come at a high cost, while customers always want the latest innovations at the lowest price.

Innovations require lots of testing using expensive prototypes and equipment. This is where mechanical simulation comes into its own by providing efficient ways to simulate any automotive part or system with a lower overall cost and less time.

Simulation provides an efficient platform for both simulation analysts and designers in one interface, improving the communication between the teams and allowing designers to perform simple simulations upward in the automobile design process. Also provides all types of high end analysis (linear, nonlinear and dynamic) in the same work environment, eliminating the tedious task of platform changing for specific analysis (Crash, Impact, Fluid dynamics...)

## Vehicle door stiffness analysis

### Introduction

Door assembly is a very important part in vehicle design because its frequent interaction with outside world. Designers faces so many different problems during the vehicle door design such as weight, cost, excessive reinforcement, water leakage, and etc. FEA analysis can help designers to reduce lead time as well as cost of design and meet various design goals.

This article introduces two common analysis types performed on vehicle doors Simulation software: Door vertical stiffness analysis and door shell stiffness analysis

## Door vertical stiffness analysis

To perform door vertical stiffness analysis, 3 principle issues need to be considered: Firstly, identify deflection between door and vehicle body due to door's weight. Secondly, identify total deformation and permanent deformation due to excessive vertical load applied to the door by careless user.

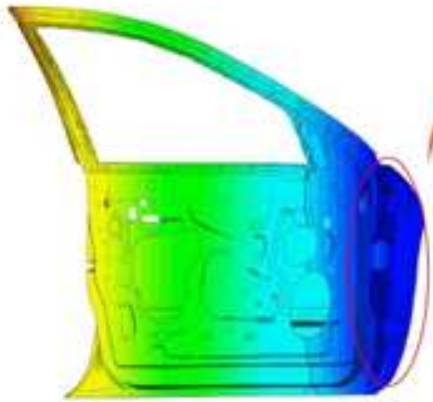

Vertical displacement distribution

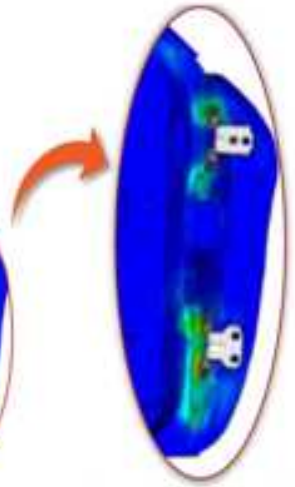

Stress distribution (Hinge)



Thirdly, perform vertical load at door latch when door hinge is restrained. By considering these issues, a finite element model is generated as above picture. Above analysis is performed by Simulation Software linear static analysis. From the result we can see displacement and stress distribution. By observing stress at hinge part we can identify if inner panel is damaged.

### Door shell stiffness analysis

Now we'll discuss door shell stiffness analysis. 2 major issues in door shell stiffness analysis are:

Firstly, stiffness needs to reach a certain level because of the high frequency of contact with the outside of the door shell. Secondly, check the deformed shape and permanent deformations due to user's behavior such as kicking the door.

Vertical Rigidity of Fixture

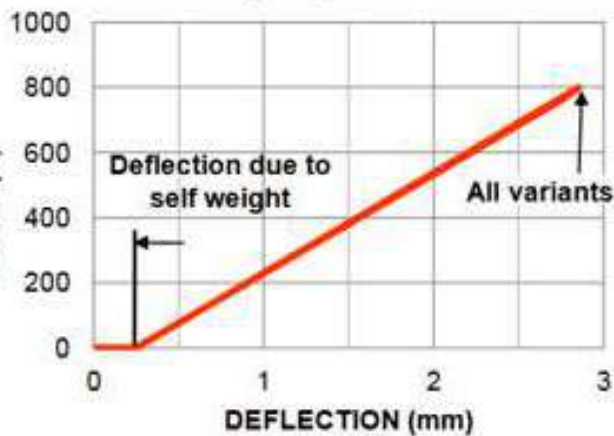

Look at the graphic above. At first the deflection is quite small due to door's self weight. However this deflection become larger when excessive vertical load is applied. Check the elasticity restoration when load is removed and make sure permanent deformation

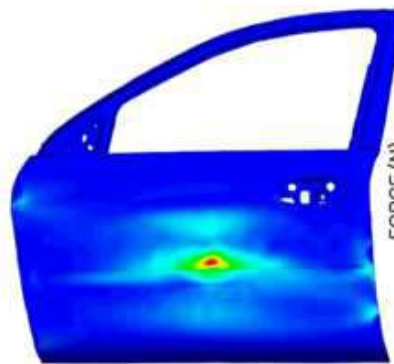

displacement distribution

Load-displacement curve

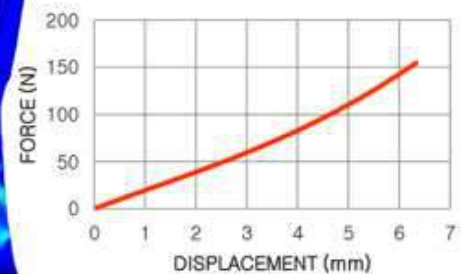

Above analysis is performed by midas NFX linear static analysis. Picture shows door shell's deformation when force is applied to the middle of the car door. And through the load - displacement curve, we can identify the stiffness of the car door shell



# Was it Designed?

by Mr. Jason D'Mello

The boxfish has a sleek design. The contours of his body allow him to swim up to six body lengths per second. The boxfish's surprisingly streamlined form inspired Mercedes-Benz's bionic concept car which is able to perform as high as 70 miles per gallon. Mercedes-Benz decided to model the Bionic after this fish due to the supposed low coefficient of drag of its body shape and the rigidity of its exoskeleton; this influenced the car's unusual looks. Other parts of the design include the fact that the rear wheels are partially fitted with plastic and that it's considered as a lightweight vehicle. Mercedes-Benz reported a drag coefficient of 0.19;<sup>[2]</sup> for comparison, the production vehicle with the lowest ever Cd value was the GM EV1, at 0.195. While the Bionic had a much larger internal volume than the EV1, the Bionic's larger frontal area made the EV1 more aerodynamic overall, as drag is a product of the area and the drag coefficient. What do you think? Did the energy-efficient boxfish come about by chance? Or was it designed?

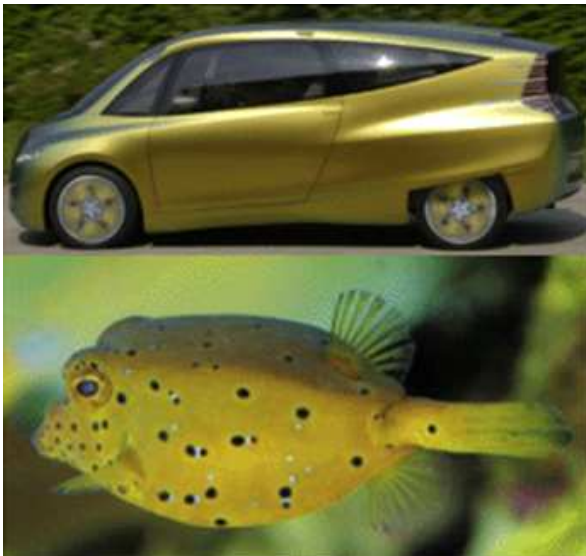

The thorny devil lizard When threatened, the reptile splays its legs wide, lowers its head menacingly and arches its spike-covered back like a tank ready for war. Oddly, the reptile assumes much the same posture during summer rains. Thorny devil lizard of the arid Australian desert is able to convey water through its body to its mouth. All this creature needs to do is find some moist sand, and the moisture will be wicked up the lizard's leg and will make its way to its mouth. Scientists hope to make a thorny-devil-inspired device that will help people collect lifesaving water in the desert. The reptile draws the water –by capillary action–through hair-thin channels between scales on its body that extend all the way to its mouth. The creature does not have to move, just swallow. Horned lizards use their water-channeling hide to suck moisture right out of the sand and, in defiance of gravity, carry water up to their mouths. What do you think? Did the moisture-extracting skin of the thorny devil come about by evolution? Or was it designed?

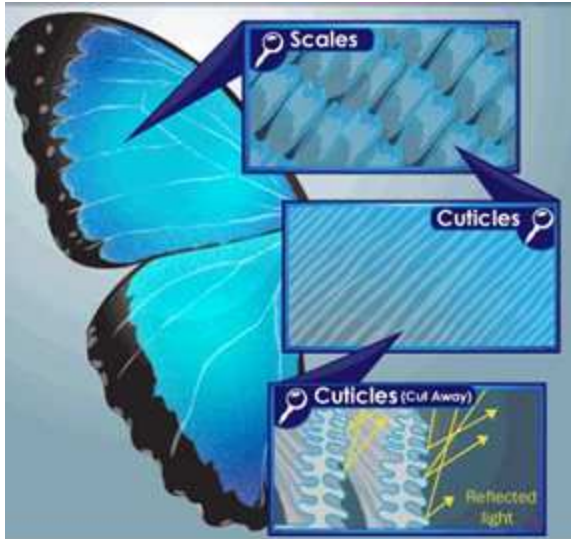

The same principle behind soap bubbles applies to butterfly wings. Their wings, however, amplify the effects of iridescence because they have many more layers for the light to pass through and thus many more opportunities for the light waves to reflect and magnify one another. As small as they are, butterfly wings are covered by thousands of microscopic scales, split into two to three layers -- thus their Greek order name, Lepidoptera, meaning scaled wings. In turn, each scale has multiple layers separated by air. Rather than having just the constructive interference from the top and bottom layer that you have in a bubble, the many, equally spaced layers of butterfly wings create multiple instances of constructive interference. Iridescence in butterflies and beetles and anti-reflective coatings in moth eyes have resulted in studies that have led to brighter screens for cellular phones and even an anti-counterfeiting technique. What do you think? Did the butterfly's wing come about by evolution? Or was it designed?

Flippers on humpback whales (*Megaptera novaeangliae*) have non-smooth leading edges, yet demonstrate superior fluid dynamics to the characteristically smooth leading edges of our wings, turbines and other kinds of blades. Whereas sheets of water flowing over smooth flippers break up into myriad turbulent vortices as they cross the flipper, sheets of water passing between a humpback's tubercles maintain even channels of fast-moving water, allowing humpbacks to keep their "grip" on the water at sharper angles and turn tighter corners, even at low speeds. Wind tunnel tests of model humpback flippers with and without leading-edge tubercles have demonstrated the fluid dynamic improvements tubercles make, such as a staggering 32% reduction in drag, 8% improvement in lift, and a 40% increase in angle of attack over smooth flippers before stalling. What do you think? Did the flipper of the humpback whale come about by evolution? Or was it designed?





# STUDENT ARTICLES



# Advanced Composite Materials in Aircrafts

Deep Vira (TE MECH B)

Advanced Composite Materials came in to existence to modify the existing materials in a way that it will enhance the physical and chemical properties of the material. ACMs are necessary in aircraft manufacturing since ACMs are light weight, more strong then conventional materials such as aluminium and fiberglass.

The aerospace industry and the manufacturers' unrelenting passion to enhance the performance of commercial and military aircraft is constantly driving the development of improved high performance structural materials. Composite materials are one such class of materials that play a significant role in current and future aerospace components. Composite materials are particularly attractive to aviation and aerospace applications because of their exceptional

strength- and stiffness-to-density ratios and superior physical properties.

Composite materials in aviation came into existence about 60 years ago when boron-reinforced epoxy composite was used for the skins of the empennages of the U.S. F14 and F15 fighters. Although it was only 2% and was used in secondary structures but as development improved its use in primary structures such as fuselage and wings has increased widely.

For example – The Airbus A350 XWB (Extra Wide Body) is the first aircraft whose primary structures (wings and fuselage) are completely made out of carbon-fibre-reinforced polymer. A350 consists of 53% composites, 19% Al/Al-Li, 14% titanium, 6% steel, and 8% miscellaneous.

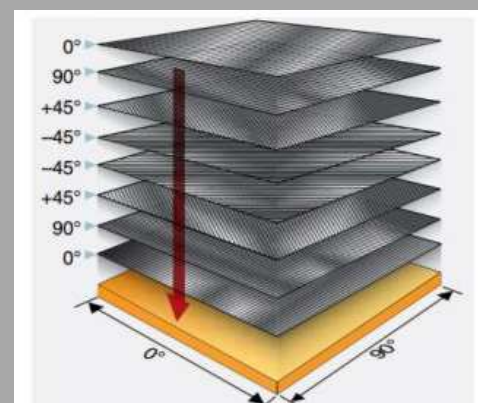
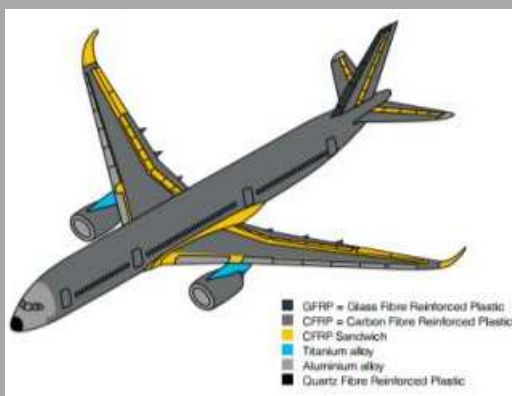



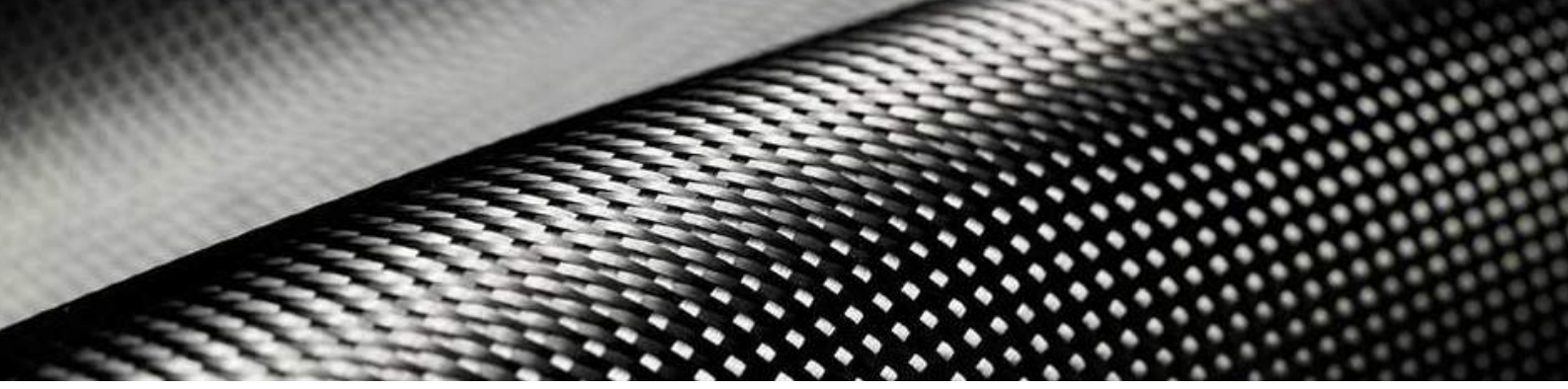

Not only has this structure improved the aircraft's performance (weight), but also its maintenance and repair procedures. It has been designed to fulfil in-service requirements with benefits such as increased resistance to accidental ground service impacts, simplified damage assessment processes and proven repair solutions.

Advantages of using composite is that they can be formed into more complex shapes than their metallic counterparts, weight reduction, formability, better corrosion resistance and good resistance to fatigue.

The B2 stealth bomber requires a radar-absorbing material to be added to the exterior of the aircraft with a concomitant weight penalty.

Composite materials are therefore used in the primary structure to offset this penalty.

The strength and stiffness of a composite buildup depends on the orientation sequence of the plies. The practical range of strength and stiffness of carbon fiber extends from values as low as those provided by fiberglass to as high as those provided by titanium. This range of values is determined by the orientation of the plies to the applied load. Proper selection of ply orientation in advanced composite materials is necessary to provide a structurally efficient design. The part might require  $0^\circ$  plies to react to axial loads,  $\pm 45^\circ$  plies to react to shear loads, and  $90^\circ$  plies to react to side loads. Because the strength design requirements are a function of the applied load direction, ply orientation and ply sequence have to be correct. It is critical during a repair to replace each damaged ply with a ply of the same material and ply orientation. This makes carbon fiber quasi-isotropic in nature.



# Underwater Turbine

by Sudhir Yadav (SE MECH B)

There are a lot of renewable energy resources sources which are used to obtain energy such as the solar energy obtained by placing solar panels, wind energy obtained by placing windmills on fields so that by wind energy it will give rise to rotation of blades and producing electricity further.

Similarly this new technique has been coming into practice to the coastal areas where the turbine blades which are used for the wind energy purpose are placed underwater near the coastal areas. Because the coastal area receives the high and low tides due to the gravitational effect by sun and moon and the rotation of earth.

Ocean currents have the tendency to produce more currents as oceans are more dense than air(they are 832 times more dense than air ),due to which it applies greater force on turbines .

Tidal energy can be produced by many technologies, the major ones are:

- 1) Tidal barrages
- 2) Tidal fences
- 3) Tidal turbines.

Hence tidal has one very distinct benefit it is virtually 100 predictable as unlike windmills which are criticized for spoiling the views on land. With underwater turbines you cannot hear it or see it and hence they are very environmentally beloved and does not produce any noise.

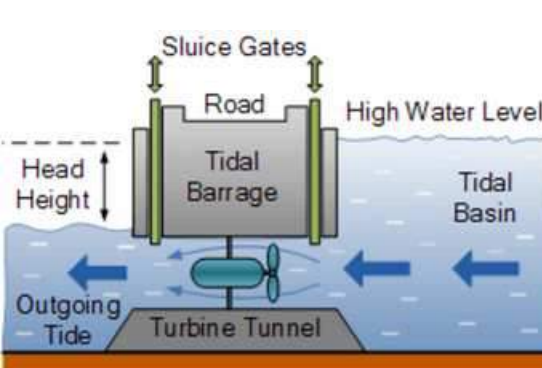

Tidal Barrages



Tidal fences

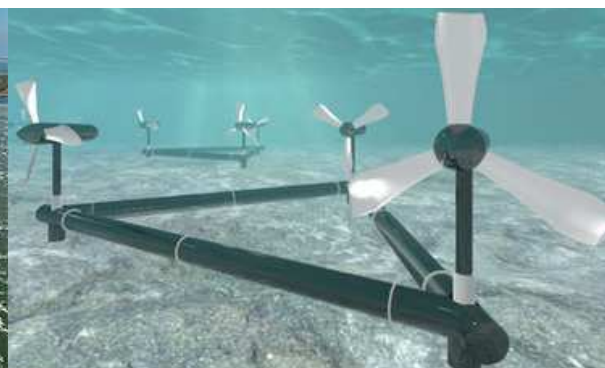

Underwater Turbines



# IC Engine with 2-stroke/4-stroke switching during its operation

by Neha Newaskar (TE mech A)

Internal combustion engine with 2 and 4 strokes, switching during its operation. The proposed improvements to conventional four-stroke internal combustion engine (ICE) accelerate its gas exchange and allow switching the ICE (especially Diesel) from four-stroke to two-stroke regime during engine operation. Scavenging in four-stroke and two-stroke mode of operation is fulfilled through the same inlet and exhaust valves.

The engine with proposed improvements is capable of doubling the engine output power and of holding it up for a certain period (time depends on a type of the engine) without overheating. This feature allows increasing the vehicle power-to-weight ratio when it is necessary in accordance with the changing vehicle operation and road conditions.

Eligible areas of activity for the proposed innovations are: (1) combat tank diesel engines, (2) combat vehicle and heavy army truck diesel engines, (3) heavy truck diesel engines, (4) special purpose vehicles diesel engines (emergency vehicles, fire trucks and others), and (5) engines in electrical generator sets.

The essence of the innovation is to improve gas exchange during the two-stroke mode of engine operation. Four-stroke gas exchange is performed like in ordinary four-stroke diesel engine.

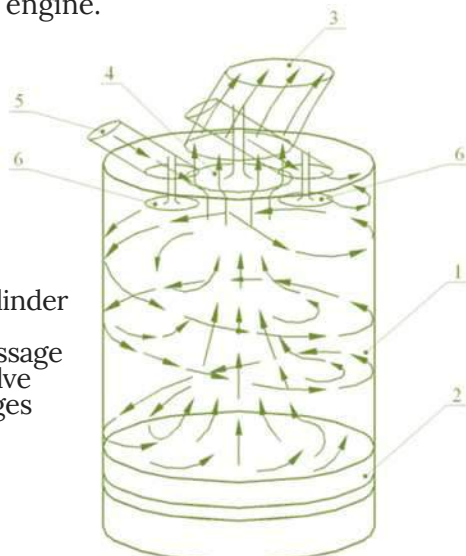

1. Working cylinder
2. Piston
3. Exhaust Passage
4. Exhaust Valve
5. Inlet Passages
6. Inlet Valve

Two-stroke gas exchange is performed through the inlet and exhaust valve unlike scavenging ports in conventional two-stroke diesel engine. Inlet valves 6 are located on of the cylinder head; exhaust valve 4 is along the cylinder axle or with a small offset. The fresh air, preliminary compressed in the engine turbocharger and additionally compressed and cooled in the supercharger with inter-cooler, is supplied into the working cylinder 1 through tangential inlet passages 5 placed at a certain angle to the cylinder head surface. Then the fresh air starts swirling as a dense bed along cylinder walls and displacing to its center and wrings exhaust gases from the cylinder walls to its axle. When the fresh air stream reaches the bottom of piston 2 it turns and expels exhaust gases, concentrated along the cylinder axle, through exhaust valve 4 into the exhaust passage 3.

To lower residual gases ratio and to cool hot surfaces, cylinder scavenging, accompanied by the discharge of some amount of fresh air charge into the exhaust system, is performed. Phases of gas exchange are typical of two-stroke conventional IC engines. Supercharger of any appropriate type with inter-cooler is complemented to conventional IC engine, the arrangement of both the inlet valves and exhaust valve on the cylinder head as well as the valve-operating system are changed in order to provide a four-stroke and a two-stroke engine mode of operation.

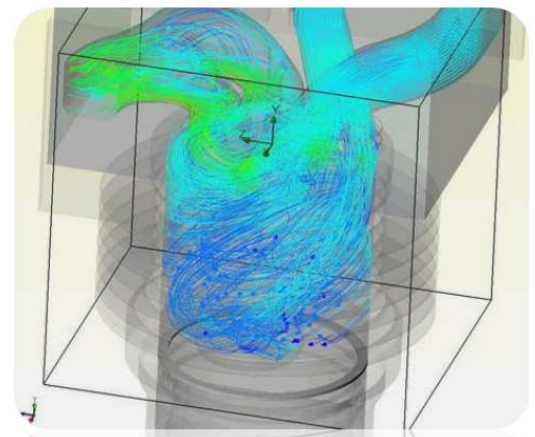





The fuel pump is selected and adjusted to provide fuel supply in correspondence with the number of working strokes.

Unlike the conventional two-stroke IC engine (especially two-stroke Diesel engine), there are no scavenging ports in the proposed design and no losses of burnt oil through them. It provides the same harmful emission as the emission in conventional diesel engines.

Fields of implementation of the innovation in details

**1. Combat tanks**

Average characteristics of modern combat tanks: a vehicle with the weight ~60 tons; max speed 72 km/h; and acceleration 0-36 km/h for 6 sec. These travel parameters are provided by 1,500 hp power plant, which is either a diesel engine or a gas turbine

. The inconsistency of a tank power plant is that the maximum power is required only for a short time of a combat tank life span – mainly during a combat or occasionally in other cases, while usually tank uses only 700-800 hp for a plain moving its weight at a constant speed and favorable moving conditions. The proposed innovation provides:

- The use of a suitable 1,000-1,500 hp diesel engine produced by any diesel engine manufacturers as a prototype for the power plant of a prospective combat tank.
- The engine prototype with proposed improvements produces 2,000-3,000 hp for a short time and doubles its power-to-weight ratio during a combat operation;

- The avoidance of designing the entirely new two-stroke diesel engine from scratch;
- Design a combat tank with the highest power-to-weight ratio and dominant maneuverability;
- The possibility of installing an additional fuel tanks inboard to increase the vehicle range without refueling

**2. Trucks**

It is possible to use the proposed improvements for civilian truck diesel engines. There is large market for the trucks with the “boosted” diesel engines like in Latin America, China, India and Southeast Asia (except Japan) countries. The truck with “boosted” diesel engine gains the ability to reach the given speed 1.7 times faster than with the conventional one. This feature is mostly useful when the truck outstrips the up-front vehicle on a counter traffic lane as well as overcomes the rise without switching the gear and slowing down vehicle speed.

The technology background includes:

1. Patents applications (both PPA and FPA) ready for submission
2. System to compute main characteristics of a targeted engine after its modification.
3. Different Solid Works models of designs, Solid Works COSMOSFIoWorks results, etc.

**Special purpose vehical**



**Tank**



**Military truck**





# The Kardashev Scale

by Aditya Tantri (SE MECH B)

The 'Kardashev scale' was developed as a way of measuring a civilization's technological advancement based upon how much usable energy it has at its disposal. Many leading researchers believe that as the population grows and expands outwards its energy requirements will increase dramatically, what with the requirements of its various technological machines. Originally, the scale was created to classify Extraterrestrial Civilizations in the event of contact and compare their technological advancement to that of humans and hence some very extreme criterias were defined for each type of civilization. As of now we aren't even a Type I Civilization.

## HISTORY:

The Kardashev was created by a Russian astrophysicist known as Nikolai Kardashev. In 1964, Kardashev came up with the idea that the status of a culture, as a whole, depends on two primary things: Energy and technology. He theorized that a civilization's technical advancement runs parallel to the amount of energy that the civilization is able to harness and manipulate. Essentially, the more energy that a society can produce, the more technologically advanced they are (this was originally just tied to energy available for communications, but has since been expanded).

In other words, according to this theory, a culture's development (in the very widest sense) is a product of energy and of technology: Through technology, energy is harnessed, and as social systems are expressions of this technology, the status of a culture rests upon (and is determined by) the amount of energy that is harnessed.

The scale has a number of different categories. In recent years, scientists have expanded this scale to measure hypothetical civilizations—civilizations that are galactic, intergalactic, and even multiverse in nature.

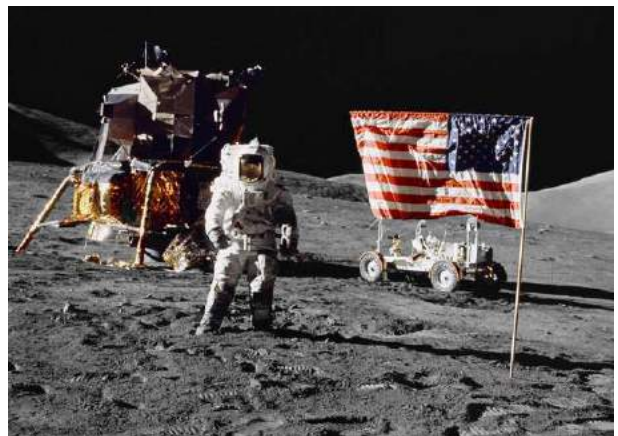

The discovery of Nuclear Power and space exploration, especially the moon landing of 1969 are huge milestones that stand as a testimony to humanity's advancement in technology. Yet we remain at the bottom of the Kardashev Scale.



• **Type 0- Subglobal Culture:** This civilization extracts its energy and raw-materials from crude organic-based sources such as wood, coal, and oil. Any rockets utilized by such a civilization would necessarily depend on chemical propulsion. Since such travel is very slow, a civilization at this level would be (for the most part) confined to its home planet. Unfortunately, this is where humanity stands now.

• **Type I- Planetary Culture:** This civilization would be capable of utilizing all available resources on their home planet, skillfully harnessing the energy output of an entire world ( $10^{16}$  watts). With any luck, we will reach this stage in 100-200 years if we are able avoid catastrophic man-made or natural disasters. Large scale use of nuclear power and renewable sources of energy such as solar and hydroelectric power will be the primary sources of energy used by this civilization. Use of Anitmatter to produce energy might also be possible.

• **Type II- Stellar Culture:** This civilization would be far more advanced than we are (a few thousand years beyond our stage of evolution). Such a society would be able to harnesses all the energy of its star (in our case, about  $10^{26}$  watts). For example, this culture might resemble the Federation of Planets, as seen on Star Trek; or the civilization might be like a majority of the humanoids in the Mass Effect universe. This civilization would use the same means of energy production as that of a Type I Civilization but on a much larger scale. The construction of Dyson Spheres around a star to collect all or most of its radiated energy would be possible for this civilization

• **Type III- Galactic Culture:** This civilization would be able to harnesses the energy output of a galaxy (about 10 billion times the energy output of a Type II civilization, and about 100,000 to 1 million years more advanced than we are). They would have colonized the galaxy itself, extracting energy from hundreds of billions of stars, traveling across interstellar space, and populating innumerable worlds. Such civilizations would have mastered interstellar travel and might use the same methods to produce energy as that of a Type II Civilization but applied to a number of galaxies which would greatly increase output. They will also most likely be able to generate energy from Black Holes and White Holes and also from Quasar emissions.

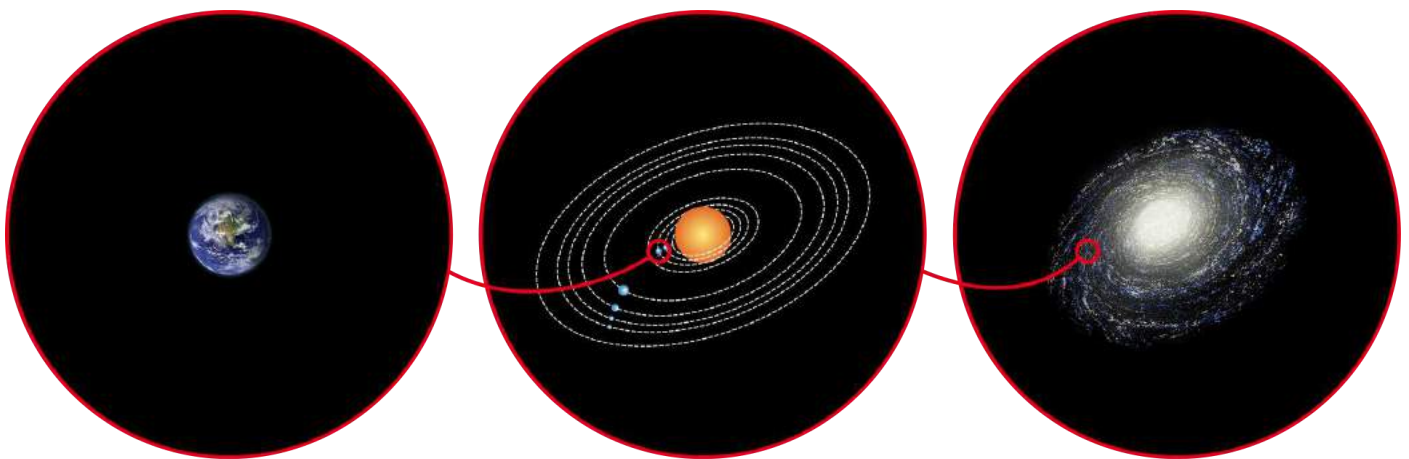

*Type I* :  $10^{16}$  W

*Type II* :  $10^{26}$  W

*Type III* :  $10^{36}$  W

**Energy consumption of Type I, II & III Civilizations**





• **Type IV- Universal Culture:** This civilization would be an intergalactic culture, spanning the breadth and width of the Universe. They would travel across the cosmos, commanding the power of a billion trillion suns. These societies would be capable of attempting projects of gargantuan, superhuman proportions, such as changing the structure of space-time or the deliberate slowing of entropy (or even its reversal) to achieve ultimate immortality. For humanity, such accomplishments might be forever beyond our reach.

• **Type V- Multiverse Culture:** This civilization will have transcended their universe of origin. It would be capable of universe-scale manipulation (jumping between multiverses that contain varied forms of matter, physics, and space-time). A civilization such as this would be home to beings of unimaginable power and ability.

Carl Sagan suggested defining intermediate values (not considered in Kardashev's original scale) by interpolating and extrapolating the values given above for types I ( $10^{16}$  W), II ( $10^{26}$  W) and III ( $10^{36}$  W), which would produce the formula:

$$K = \frac{\log_{10} P - 6}{10},$$

where value K is a civilization's Kardashev rating and P is the power it uses, in watts.

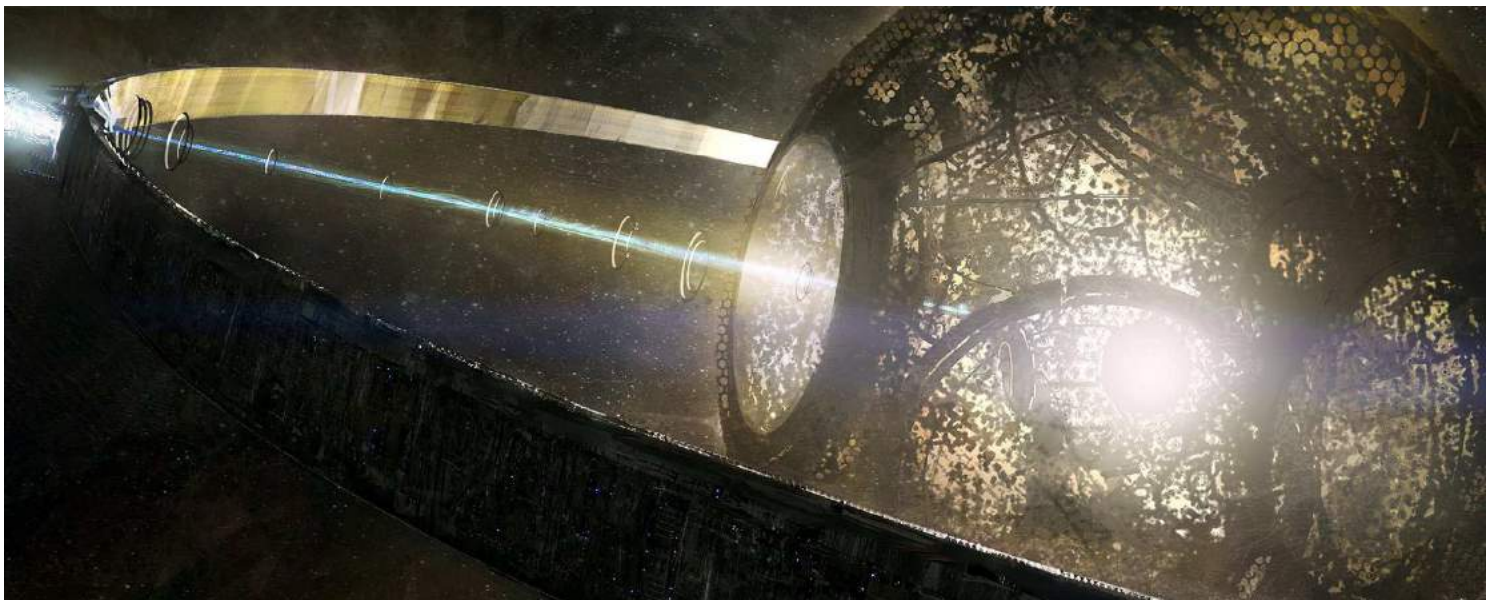

**An artist's rendering of a Dyson Sphere constructed around a star to harness its energy.  
A feat possible for a Type II Civilization**

# Ultra Efficient Jet Engines

by Raj Oak (TE MECH A)

Pollution by aviation is one of the major causes of global temperature increase and Ocean acidification caused by the release of carbon dioxide and other greenhouse gases into the upper part of Earth's atmosphere. Globally around 8.3 million people fly daily, twice the total in 1999, burning almost 500,000 metric tons per day. With no much advancement in the alternate fuel research currently same old gasoline is being used causing ever increasing pollution, and many in industry believe the pathway to cleaner jets is through advances in engine technology rather than cleaner fuel.

That's the main idea behind tomorrow's aircrafts with engines that are much lighter, quieter, durable and more energy efficient than the conventional turbofan engines used today in commercial airliners today. Pratt & Whitney is an aerospace manufacturer which has introduced a new series of engines called 'Pure Power' which uses an internal gearbox to slowdown the speed of the fan. The technology effectively saves 16% on fuel consumption compared to the airliners with conventional engines. Meanwhile CFM International aviation mogul which is a joint venture between GE Aviation and Safran Aircraft Engines has introduced its own advanced engine, called the 'Leap', which could achieve similar improvements without a huge break from existing technology. Both new engines have been deployed on different versions of Airbus's new jet the A320neo.

Pratt & Whitney first attempted to build a geared turbofan starting around 1998 with PW800. Soon afterwards Advanced Technology Fan Integrator (ATFI) project commenced using the engine PW308 at the core but along with a new gear box and a single stage fan.

It had its first run on March 16, 2001. This led to the geared Turbofan program which was developed with German MTU Aero Engines. In addition to Turbofan, initial design included variable area fan nozzle which allows improvements in propulsive efficiency across a range of flight. GTF was then renamed as PW1000G, the first in new line of "PurePower" engines.



In the PurePower 1000G engine family, a state of the art gear system separates the engine fan from the low Pressure compressor and turbine, allowing each of the modules to operate at their optimum speeds. This enables the fan to rotate slower and while the low pressure compressor and turbine operate at high speed, increasing engine efficiency and delivering significantly lower fuel consumption, emissions and noise. This increased efficiency also translates to fewer engine stages and parts for lower weight and reduced maintenance costs. This high-bypass geared turbo fan engine is 16% more fuel efficient as well as being up to 75% quieter. It has a 3:1 gearbox between the fan and the low pressure spool, each spinning at its optimal speed of 4000-5000 rpm for the fan and 12,000-15,000 rpm for spool, the high pressure spool is spinning at more than 20,000 rpm. The 30,000 hp gearbox is designed to run lifelong with no scheduled maintenance other than changing oil.





CFM International introduced their LEAP engine intended to compete with Pratt & Whitney PW1000 engine. This engine basically makes use of advanced material composites and different cool air mixing cycles modulating the amount of air flow to the internal passages inside its high pressure turbine to keep the temperature under control. The fan used in the engine has flexible blades manufactured by a resin transfer molding process, which are designed to untwist as the fans rotational speed increases. Currently proposed for the LEAP is a greater use of composite materials, a turbine fan in the compressor, a second generation Twin annular Pre Swirl combustor that cuts the nitrous oxide emissions in half, and a bypass ratio around 10:1. The company is using ceramic matrix composite to build the turbine shrouds.

CFM developed a new carbon-fiber blade whose design involves weaving individual carbon-fiber strands on gigantic Jacquard looms into a complex, three dimensional laminate and infusing epoxy resin into the structure by means of a proprietary transfer molding technique. .

Each individual blade consists of 7 kilometers of carbon-fiber and after being cured in autoclave the finished blade is strong enough that an entire Airbus A350 could be suspended from it without the blade breaking

CFM uses a ceramic composite matrix (CMC) material consisting of silicon carbide-and-graphite matrix. Each shroud is a ring of 36 tightly fitting white colored CMC parts forming a ring round the inside of the HTP casing outside the circumference of the first HTP rotating stage. Combining all the material advantages these engines are saving fuel by almost 15%.

To sum up these new technologies competing each other for the ultra-high efficiencies has made it possible to look into future jet engines or at least bridge the gap between today's and tomorrow's engines providing a durable, low maintenance, highly efficient, cleaner, less noisy and advanced engine indicating a reliable future of aircraft industry.

# Tesla Turbines

by Saurabh Vaidya (TE MECH B)

**ABSTRACT:** The Tesla turbine is a non-conventional bladeless turbine which works on the principle of boundary layer. It consists of a number of parallel discs fixed on a shaft with gaps between the discs. The fluid is made to flow tangential to the discs inside a casing. Momentum is transferred from the fluid to the discs due to viscous and adhesive forces.

**INTRODUCTION** Turbomachines are machines which convert fluid energy into rotational motion. Tesla turbine, also called as Prandtl turbine and boundary layer turbine, is a nonconventional turbomachine which operates on the principle of boundary layer. It does not use friction for its working, instead it uses adhesion and viscosity for its functioning. Energy is transferred from fluid to the rotor by dragging discs mounted on the shaft due to boundary layer effect. Fluid flows tangentially towards the discs, follows a spiral path towards the center and exits axially. The fluid loses its kinetic energy to the discs, thus causing the rotation of rotor. Both compressible and incompressible fluids can be used. The manufacturing of Tesla turbine is much easier compared to the conventional turbines. Also, the turbine is unaffected by the quality of the fluid, thus can be used with fluids containing particulates. A tesla turbine is a reversible turbomachine therefore it can be used as pump. In a pump configuration, the fluid enters axially near the center. The discs provide energy to the fluid, following a spiral path and thereby exiting from the periphery.

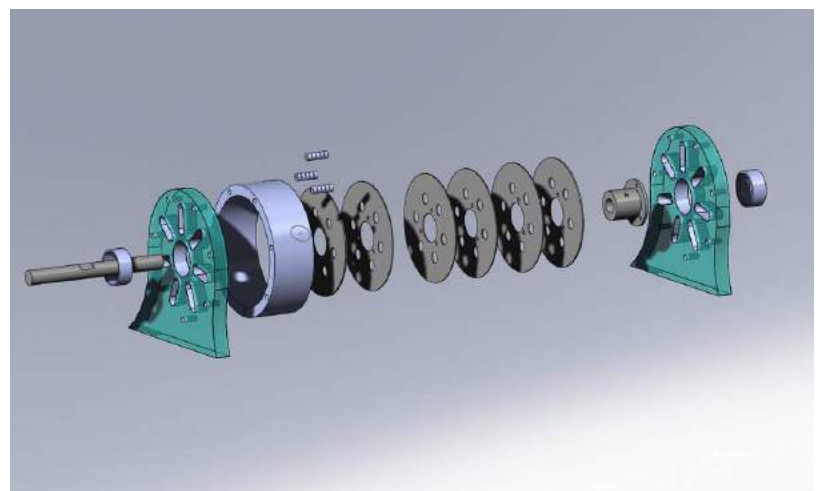
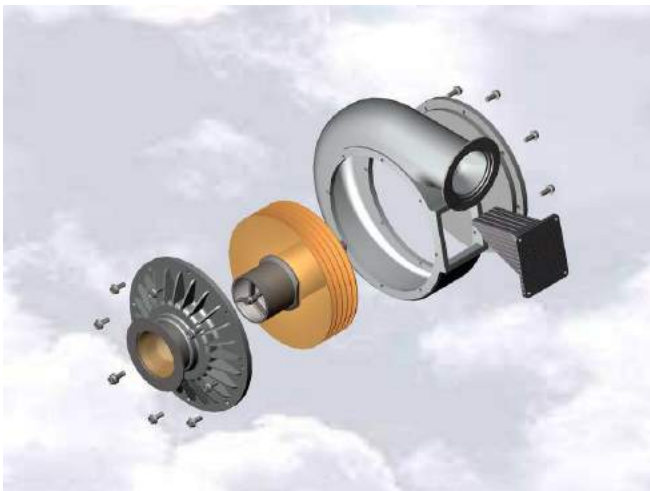





**CONSTRUCTION AND WORKING:** The Tesla turbine consists of a number of discs mounted parallel to each other on a shaft. Nozzles are located at the periphery of cylindrical casing and tangential to the shaft, pointing toward the inside. The discs are separated by thin gaps for the fluid to pass through it. Exhaust ports are located near the center of the turbine.

Fluid enters tangentially into the turbine from the periphery. It is made to enter the gap between the discs. The moving fluid drags the discs in the direction of the flow. Due to this there is a transfer of kinetic energy from the fluid to the discs. This transferred energy causes the discs to rotate with the shaft. The fluid thus slows down as it moves towards the centre in a spiral path exiting from the exhaust ports.

**FACTORS AFFECTING PERFORMANCE:** Performance of tesla turbine is affected by various parameters. Few of them are:

- Number of discs: The number of discs can be increased to increase the torque obtained.
- Dimension of the discs: The inner and outer radius determine the length of the spiral path followed by the fluid. The more the area of the discs the longer path will be travelled by the fluid.
- Size of the gaps between the discs: The thickness of the gap should be equal to twice the boundary layer thickness.
- Number of nozzles: The torque obtained will be increased if the number of nozzles are increased.
- Reynolds number: The laminar boundary layer thickness depends upon the Reynolds number.
- Velocity of the flow: The velocity of the fluid causes the kinetic energy which is transferred in the turbine.

**APPLICATIONS:** Tesla turbine was designed to use fluids as motive agents to rotate the rotors. It is found to be useful in low power applications but lacks in performance in high power applications. Many experiments have conducted using tesla turbines for various applications such as steam turbines, turbo for automobiles. One of the most important applications of Tesla turbine is that it can be used where the working fluid contains particulates such as salt water or impure water. It also has applications when working with low and high viscous fluids. Though Tesla turbine has not been successful in finding commercial utilization since its inception, Tesla pump on the other hand has been widely used in applications which require pumping abrasive fluids such as industrial waste etc. Tesla pumps for blood transfusion have become widespread.

**CONCLUSION:** The tesla turbine is a nonconventional promising technology that is yet to be fully researched and optimized. More applications are yet to be studied and developed. Complete optimization of tesla turbine performance is beyond the scope of this paper.

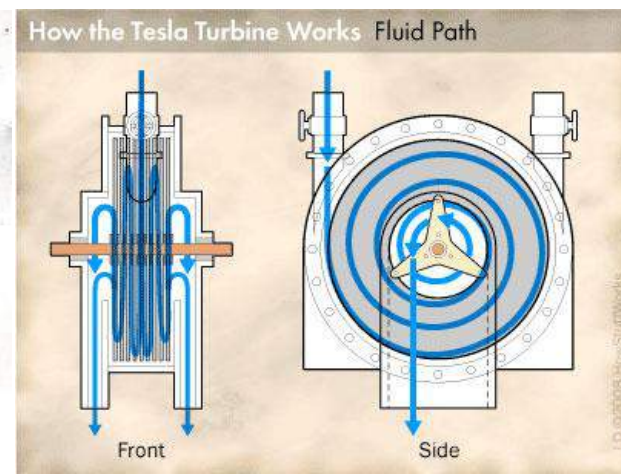
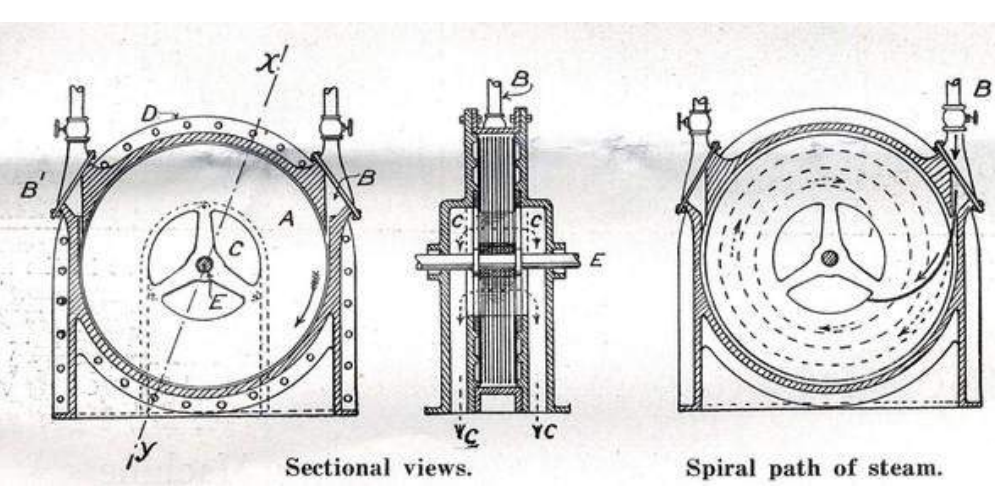

# Hydrogen : Future's Fuel

by Avinash Gupta (TE MECH A)

Hydrogen is one of the most abundant and promising fuel source available in the air. It is lighter than air and incredibly pure. When used in the fuel cell, it is highly efficient and leaves no carbon emission behind. And best of all, it is virtually everywhere. It is found everywhere in the plants, water, manure, etc. But the problem arises before it can be used; it has to be separated.

## There are a lot of ways to produce hydrogen:-

### I. Steam reforming:

Steam reforming of methane is the most common method for the hydrogen production. It combines methane with the high temperature steam to trigger a reaction and separate the hydrogen. At high temperatures (700 - 1100 °C) and in the presence of a metal-based catalyst (nickel), steam reacts with methane to yield carbon monoxide and hydrogen.

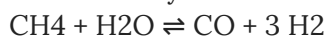

### II. Gasification:

Gasification is a process that converts organic or fossil fuel based carbonaceous materials into carbon monoxide, hydrogen and carbon dioxide. This is achieved by reacting the material at high temperatures (>700 °C), without combustion, with a controlled amount of oxygen and/or steam.

### III. Electrolysis:

Hydrogen can also be produced by separating water into its two primary elements—hydrogen (H<sub>2</sub>) and oxygen (O<sub>2</sub>). This process, known as electrolysis, passes an electrical current through the water to extract hydrogen. The electricity can be sourced from clean, renewable energy such as wind, solar, or hydro.

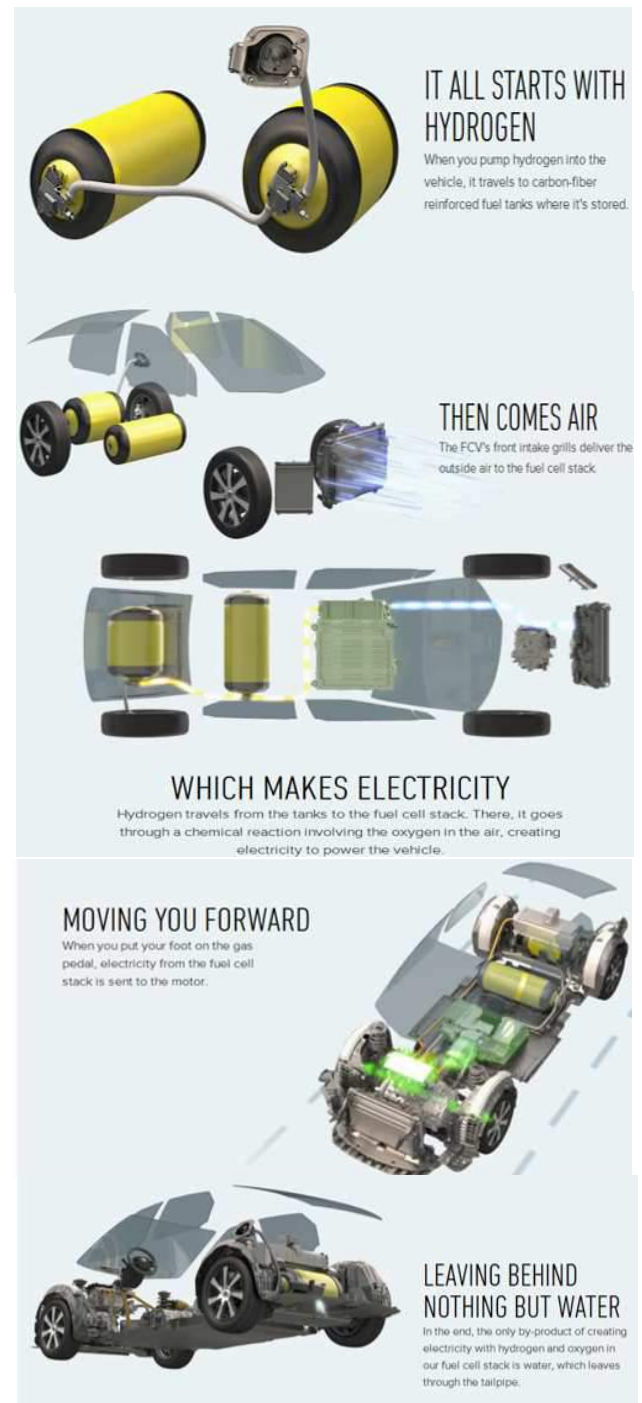
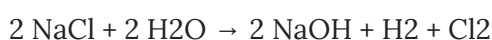





### FCV concept (using hydrogen):

One such FCV (Fuel Cell Vehicle) concept car is Toyota mirai. The unveiled FCV concept was a bright blue sedan shaped like a drop of water "to emphasize that water is the only substance that hydrogen-powered cars emit from their tailpipes. The FCV uses Toyota's proprietary, small, light-weight fuel cell stack and two 70 MPa high-pressure hydrogen tanks placed beneath the specially designed body. The Toyota FCV concept can accommodate up to four occupants.

The FCV concept also uses portions of Toyota's Hybrid Synergy Drive technology including the electric motor, power control unit and other parts and components from its hybrid vehicles to improve reliability and minimize cost. [18] The hybrid technology is also used to work together with the fuel cell. At low speeds such as city driving, the FCV runs just like any all-electric car by using the energy stored in its battery, which is charged through regenerative braking. At higher speeds, the hydrogen fuel cell alone powers the electric motor. When more power is needed, for example during sudden acceleration, the battery supports the fuel cell system as both work together to provide propulsion

#### High-pressure hydrogen tanks

The Mirai has two hydrogen tanks with a three-layer structure made of carbon fiber-reinforced plastic consisting of nylon 6 from Ube Industries and other materials.

The tanks store hydrogen at 70 MPa (10,000 psi). The tanks have a combined weight 87.5 kg (193 lb) and 5 kg capacity.

Safety features:

1. multi-patented, carbon-fiber-wrapped, polymer-lined tanks are built in a three-layer structure and absorb five times the crash energy of steel.
2. In a high-speed collision, sensors stop the flow of hydrogen.
3. Any leaked hydrogen is quickly dispersed. Since the gas is lighter than air, it rapidly disperses, reducing the time window to cause damage in the event of an ignition.

Thus with the help of scientific studies and curious minds if we can create and store this hydrogen easily then it would be revolution in the field of technology. As we would get efficient and pollution free energy for the future. Thus encouraging the concept of sustainable development.

# MINI PROJECTS







# Multifunctional Robot for Fault Detection in Pipeline

Omkar B, Tanmay D, Mayank D, Raj O, Meet L, Avinash G

**Abstract:** The robot is specially constructed so as to travel inside a pipeline to detect cracks and faults. It consists of a cylindrical body with protruding and spring loaded wheels that will facilitate its travelling inside a pipe. The body will also be equipped with various sensors like; ultrasonic sensor, IR sensor, proximity sensor, camera. This project was initiated keeping in mind the fact that these days most of the equipment used for pipe fault detection is used on the outside of the pipe rather than inside.

Pipelines carry majority of the natural resources over large distances. Since it's a man-made structure there is large number of faults present in them. These faults are unavoidable; but we can always detect them beforehand and prevent any accident from occurring. There have been many incidents in the past where pipelines underneath a city just blew up destroying the infrastructure and also causing grave damage to humankind.

There have been many machines invented which are used to check for defects in a pipeline; but the problem with conventional machines is that they can only work outside of the pipe. Moreover they are obsolete and very difficult to transport & maintain.

We have designed a solution for this very problem. The robot will travel inside the pipe and will constantly keep checking for cracks, leaks and faults on all sides. This bot is equipped with spring loaded wheels that enable locomotion in pipes of varying diameter. The bot will have R/F transmitter that will be used for communication with the user. This bot was designed keeping in mind the above stated problems and will surely help in averting severe accidents which would have caused damage to life and property.

## WORKING

The bot has been made keeping in mind many of the hindrances that it will face inside a damaged pipeline. The bot will have three wheels on each end of the chassis that are spring loaded. Also the material used will be non-reactive so that it can work in pipelines that contain chemical deposits. Initially the bot will provide a visual image of the pipe via the camera allowing user to see if there are any obstacles in the path. The ultrasonic and proximity sensors will start functioning and provide the data about the condition of the pipe.

Both the R/F transmitters will be configured, one as a receiver and the other as a transmitter. Communication will be established between them once the robot starts working. The bot will be in constant connection with the user wirelessly

## INDUSTRIAL APPLICATIONS

There are numerous industrial applications for a robot of this stature. Some of the largest ones are pipeline and petroleum industries which use plethora of pipes for the functioning of their business. Pipes are evidently present in each and every industry; thus their failure may lead to adverse accidents. This bot has a lot of scope for improvement as well. On discussing with industry specialists many new applications will come up. The future scope of this bot is quite promising as well. The robot could be attached with a cleaning unit that will simultaneously clean the pipe from inside while detecting flaws. The robot could be designed in such a way that it does not require its own power for propulsion, instead it will use the trapped fluid power of fluid that is flowing through the pipe by a vane mechanism. The bot could be designed in such a way that it could detect fault even if the fluid is flowing through the pipe and a unique turbine system can be designed to convert some part of flowing fluid into electricity which could be used by on board systems for their power requirement eliminating the limit of use due to low battery storage capacity.

# Automatic Sensor Based Wall Painting Robot

Neha N, Shivam M, Champak M, Sampada C

## INTRODUCTION:

Building and construction is one of the major industries around the world. In this fast moving life construction industry is also growing rapidly. But the labors in the construction industry are not sufficient. The primary aim of the project is to design, develop and implement Automatic Wall Painting Robot which helps to achieve low cost painting equipment. Despite the advances in robotics and its wide spreading applications, interior wall painting has shared little in research activities. The painting chemicals can cause hazards to the human painters such as eye and respiratory system problems. Also the nature of painting procedure that requires repeated work and hand rising makes it boring, time and effort consuming.

## CONSTRUCTION:

The construction of the automatic wall painting robot consists of the following main parts:

- Frame stand
- Wheels
- DC motor
- Battery
- Control unit
- IR sensor
- Spray gun
- Pump
- Links



## WORKING:

This is project mechanism work on principle of “SCISSOR LIFT MECHANISM”. A scissors lift uses linked, folding supports in a criss-cross 'X' pattern, known as a pantograph. The extension is achieved by applying pressure to the outside of a set of supports located at one end of the lift, elongating the crossing pattern. This is achieved through mechanical means. It may require no power to return to its original position, but simply a release of the original pressure. This consists of a paint pump, paint tanks (for primer and overcoat), a compressor to drive the pump, and a reel to wind up the paint hose.

## USES:

- The aims and objectives of the project are to design a system for painting of wall which is:
- Autonomous
- Efficient
- User-friendly
- Transportable
- Cost-effective
- Reduce strenuous and repetitive task
- Increase safety



# An Integration of IoT using Arduino and Android smartphone

Mayank D, Vishal G, Sandeep J

## OVERVIEW:

We love some good LED blinking as much as the next person but after years of LED-soldering we need something cooler to get us excited. Sure there are RGB LEDs and those are fun too but what comes after that? Well, we have the answer: "LED Strips". Isn't it full of excitement if you can control the LED strip colour on your mood just by using your android smartphone ! Of course you can.

## REQUIREMENTS AND USAGE:

1. Arduino uno board-
2. HC-05 bluetooth module-
3. 220 ohm resistors-
4. Jumper wire-
5. Breadboard-
6. Android smartphone-
7. LED Light

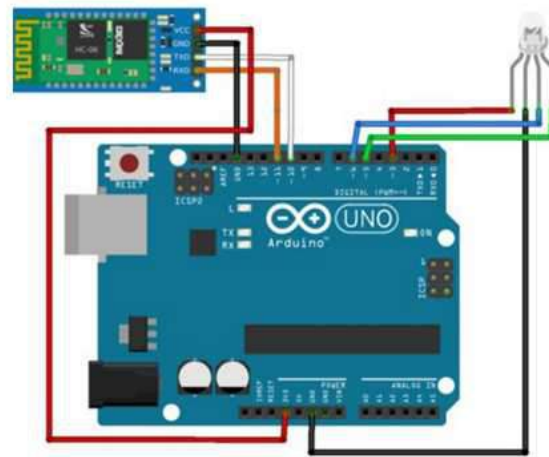

## DESCRIPTION:

The Arduino is connected to the Android smartphone through HC-05 Bluetooth module. The android app is specifically designed to send commands of color in the form of RGB (0-255,0-255,0-255). The LED is connected to the Arduino via pins 3, 5 and 6. These pins are chosen since they are PWM pins in Arduino. Thus, any colour chosen through Android smartphone can be displayed in LED light and thus sets an example of integration of Internet of Things.

## APPLICATION:

When you use Color Changing LED, you no longer have to decide which color to use. You can either allow the lights to cycle through a continuous color changing pattern, or stop the controller at any color you like. The possibilities are endless.

Change your color scheme with the seasons, or simply at your whim with RGB Color Changing LED lights. RGB LED contain red, blue and green LEDs which combine to give desired Color output. There are literally more than 16,000,000 possibilities with the more sophisticated controllers.

# Laser Engraver

Deepak P, Deepak M, Yagnesh Y

## INTRODUCTION:

Laser engraving, which is a subset of a laser marking, is the practice of using to engrave an object. The technique does not involve the use of inks, nor does it involve tool bits, which contact the engraving surface and wear out, giving an advantage over alternative engraving and marking techniques, where inks or bit heads have to be replaced regularly.

## WORKING:

- This project is basically an mini CNC laser engraver, which is made up of 2 dvd drives, arduino uno, LM293D motor drivers, 200mw 650nm laser and GRBL controller software (as G-code cannot be uploaded directly into arduino).
- The drives are dismantled and arranged into x-y axis respectively.
- The arduino uno is used to control the servo motors in the DVDs, and also controls the laser.
- The required g-code is being sent to the arduino with the help of GRBL controller.
- As soon as the code is uploaded the engraving starts.

## SOFTWARES REQUIRED:

- Arduino IDE
- GRBL controller
- Inkscape

## APPLICATION:

Industrially such engraver can be used to a large extent but as our laser is of just 100mw it can performs following functions

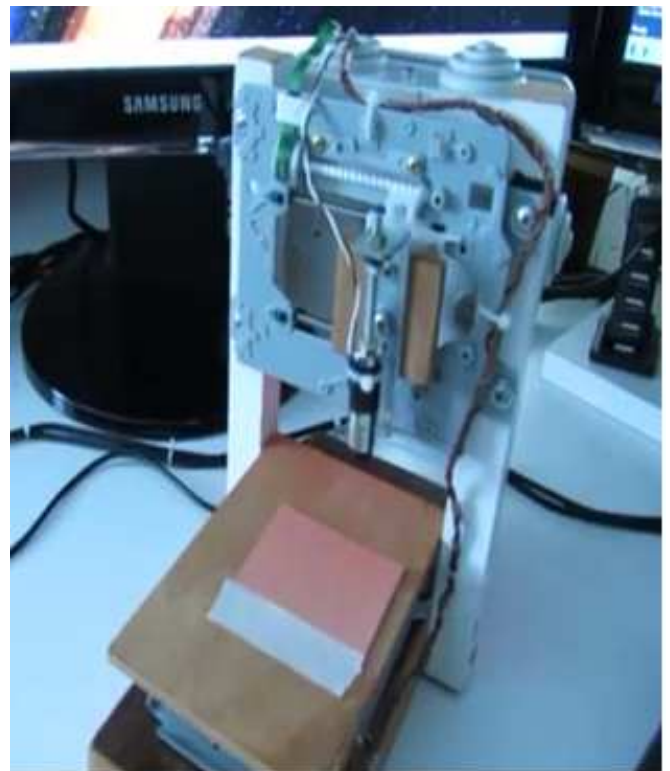



# Arduino LED Auto Intensity Control

**Rohit T, Hariom S**

## **INTRODUCTION:**

Power consumption and cost effectiveness. Automation is intended to reduce man power with the help of intelligent systems, Power saving is the main consideration forever as the source of the power (Thermal, Hydro etc.,) are getting diminished due to various reasons. The main consideration in the field of technologies are Automation.

Street lighting is a particularly critical concern for public authorities in developing countries because of its strategic

lighting wastes significant financial resources every year, and poor lighting can cause accidents. Use of Energy efficient technologies can reduce cost of the street lighting drastically and also provide excellent efficiency.

We want to save power automatically instead of doing manual, so it's easy to make cost effectiveness. This saved power can be used in some other applications, such as in irrigation, villages, towns and many other fields. We can design intelligent systems by using Arduino to control intensity of street lights. The idea of designing a new system for the streetlight by using LED that do not consume huge amount of electricity and illuminate large areas with the highest intensity of light whenever required.

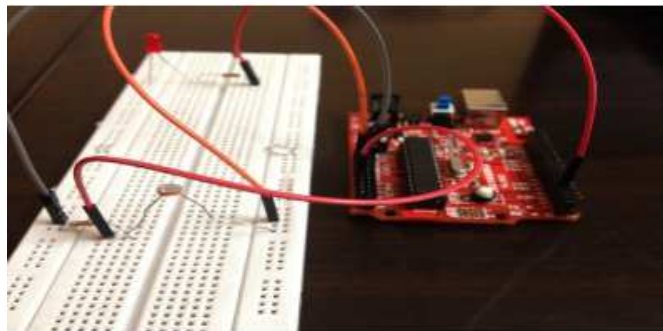

## **WORKING:**

1. Two kinds of sensors will be used which are light sensor like LDR and Photoelectric sensor.
2. The light sensed will detect darkness to activate the ON/OFF switch, so the streetlights will be ready to turn on and the photoelectric sensor will detect movement to activate the streetlights.
3. LDR, which varies according to the amount of light falling on its surface, this gives an induction for whether it is a day or night.
4. The photoelectric sensor will be activated only in the night. If any object crosses the photoelectric beam, a particular light will be automatically ON.

## **APPLICATIONS:**

1. It can use in irrigation, villages, towns.
2. It will Provide street lighting in typical cities worldwide.
3. 24 hours change of daylight, the highly changeable traffic, the variable meteorological conditions and some extreme situations on the roads, the intensity of street lighting should change in a dynamic manner.

# Belt Driven Mechanism

- Jay P, Shlok P, Aniket Y, Atesh S

Belt driven Mechanisms are used to transmit power from one shaft to other by the means of pulley which rotates at a same speed or at different speeds. Power transmission depends on following factors:

- The velocity of belt.
- The tension under which the belt is placed on pulley.
- The arc of contact between the belt and smaller pulley.
- The shaft should be in proper line to insure the uniform tension across the belt section.

## Types of Belts are :

1. Flate Belt – used in factories and workshops where moderate amount of power is to be transmitted.
2. V belt- used in factories and workshops where moderate amount of power is to be transmitted from one pulley to another when two pulleys are nearer to each other.
3. Circular Belt- used in factories and workshop where great power is to be transmitted, from one pulley to other.

## WORKING:

We use a motor in this mechanism. This motor is used to provide a power to the mechanism. This motor is connected to a shaft with pulley on shaft by using a belt. In this case we use a FLAT BELT.

which transmit power from motor to shaft. Due to this the shaft will rotate and while the shaft is rotating the links connected to shaft will rotate resulting in the rotation of leg of this mechanism. This rotation will help in movement of this mechanism. There are other 2 shafts which are connected to their respected links which are used for supporting purpose for smooth movement of leg.

## APPLICATION

- It can be used for load carrying purpose. Since it can be used for carrying load so it can be used in assembly lines for load carrying in factories or in workshops.
- By the design we used it can be used in all geographical places. Hence, at time of emergencies it can be useful.

## FUTURE SCOPE

In future the design we used for building the robot will dominate the industry. In factories and in workshops we can use for carrying loads. The only thing we have to look is its maintenance.





# Cam and Follower

- Tejinder S, Pranav P, Rahil P, Yogesh R

A cam is a rotating machine element which gives reciprocating or oscillating motion to another element known as follower. The cam and follower have a point or line contact constituting a higher pair.

The contact between them is maintained by an external force which is generally provided by a spring or sometimes by the weight of the follower itself when it is sufficient.

The cam converts rotary motion of one element into reciprocating (linear) motion or into oscillatory motion.

The cam is the driver member and the follower is the driven member.

Cam followers are often used on conveyors, process transfer lines, such as those used in industries such as food and beverage, plastics, glass and among others. AST cam followers are also popular for defense and aircraft applications, where maintainability and system reliability are important design considerations. To smoothly and evenly distribute the loads, cam followers usually are designed with a full complement of rolling elements.

However, there is more than one type of configuration for cam is mounted to its counterpart.

Future trends to reduce, control and overcome scuffing in cam-follower system are recommended, such as:

1. The future for improved scuffing resistance of cams and their followers lies with the field of surface coating, cladding treatments, metallic material composite and multi-layer soft materials. 2. In designing to avoid failure by scuffing in cam-follower system, factors must be taken into considerations such as rich lubrication, low contact temperature, material selection and processing.

3. Surface roughness value and texture play an important role in scuffing mechanism. Therefore, it ought to be taken into consideration during manufacturing process of cam-follower system.

4. The adequate choice of properties of lubrication; such as viscosity, friction etc. Therefore, if economics allow, the modern lubricants such as the liquid crystal, and electro rheological fluid may be used.

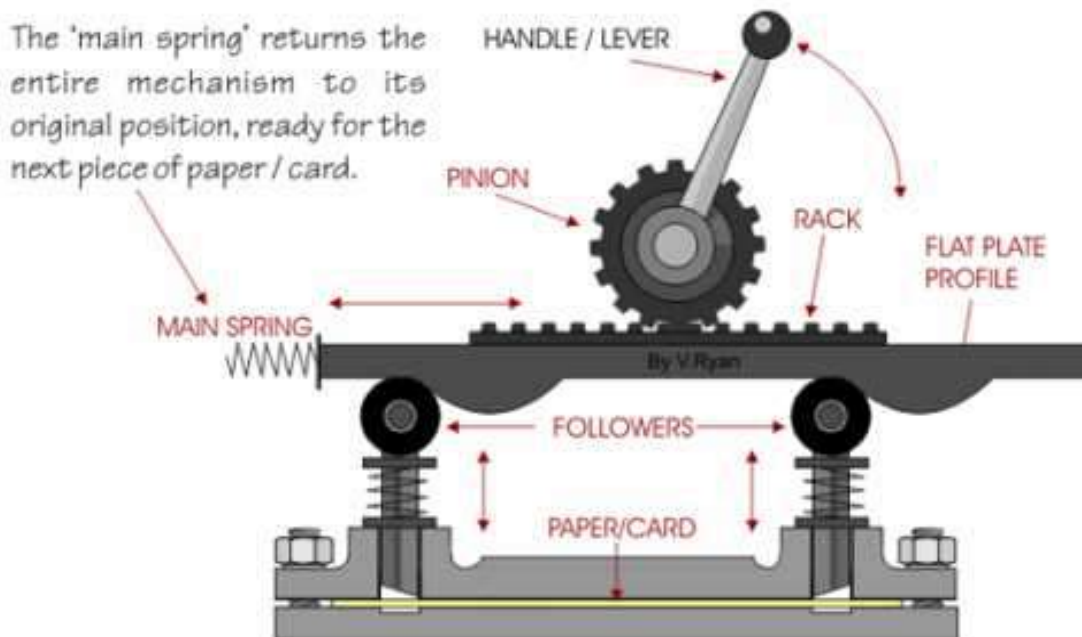

# Robotic Gripper

- Sarthak N, Kshitij N, Kaustubh P, Atharva P

Robots are uniquely designed in order to effectively complete specific tasks. The task-specific design of robots has made them an invaluable component in the industrial production environment. Robots are now entering the consumer market and, once again, their task-specific design makes them beneficial in performing common household tasks. Devices specific to a robot's end use are incorporated into design to complete defined tasks. End-effectors are one such device. These are mechanical devices mounted on some part of a robot, usually at the end of a robot's arm. End-effectors, more commonly referred to as grippers, act as an important interface between the robot and its environment. The sole task of a gripper is to grasp and release objects during robotic manipulation (Guo et al, 1992).

Robotic grippers are end-of-arm devices that are most commonly used for material handling in industrial situations. Grippers are designed to grasp and release specific objects. Grippers range from match-box size devices to industrial machines capable of several thousand pounds of force (Spencer, 2005). Obviously, the design of robotic grippers depends on the specific grasping task. "The challenge to the gripper designer is to address these requirements while at the same time, create a cost-effective mechanism that is lightweight, satisfies packing requirements, and can be manufactured and scaled to create a product family (Spencer 2005)."

Robotic grippers are often classified by the shape of their gripping mechanism. Gripper types include angular, parallel, collet, vacuum, magnetic, needle and expansion (Spencer, 2005). Gripping of most objects requires that the object be centered in the grip. This is called synchronous gripping, while asynchronous gripping refers to gripping that does not require object centering. Collet grippers have a round shape and use a sliding taper that tightens around and grips the object. Collet grippers can accommodate a size window of objects.

This window is based on the stroke length of the collet. Collet grippers are one of the best grippers for part centering (Spencer, 2005).

At present the majority of industrial robotic grippers are designed for one specific purpose and their gripper design must be retooled for different uses (Hardin, 2005). Shape specific grippers allow the gripper only to grasp very specific object geometry. Some shape specific grippers can be swapped out to accommodate grasping a variety of different object geometries by a single robot. However, gripper swapping requires significant time away from production. Most grippers must be modified by the gripper manufacturer to accommodate new object geometries.

There is a growing focus on multi-use design for robotic grippers. Hard stops and sensors allow engineers to design multi-use flexibility into their devices. Hard stops can customize the stroke length of a gripper in order to provide for a multi-use application without requiring a specially designed tool on the effector. Also, a robot with multiple fingers can grasp and move a variety of items that fit within their grip length and grasp specifications. Multi-use grippers allow robots to grip multiple geometries, allowing grippers to be used for a single application within a family of possible object geometries to grip.

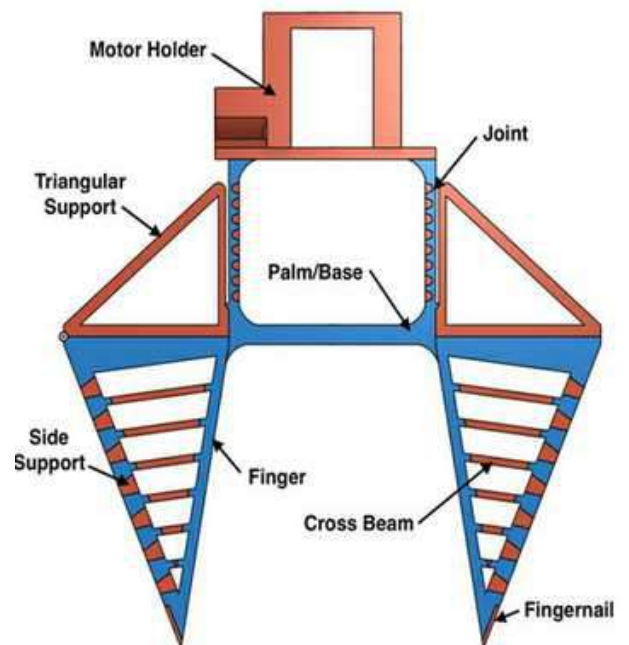



# Robotic Gripper

## Applications:

### GRIPPERS FOR MEDICAL APPLICATIONS:

In use of robotic grippers in surgery, one of the main issues is the lack of force feedback and damaging the biological tissues. Soft bodied grippers are very suitable in the medical field based on their self-limiting and intrinsic safety features, which provides safe interaction with biological tissues.

### APPLICATIONS OF ROBOTIC GRIPPERS:

#### GRIPPERS FOR INDUSTRIES:

The earliest grippers were first developed for industrial applications. They are commonly defined as grippers used for mass production purposes that are mounted on a stationary platform.

The industrial grippers can be studied through different aspects such as geometrical condition of grasping, position and orientation of grasping, static equilibrium of grasped object, and dynamic conditions. We mainly focus on the performance, adaptability and flexibility of the grippers.

#### GRIPPERS FOR FRAGILE OBJECTS:

With the improvement of end-effector sensors, the idea of picking up fragile objects was explored.

An end-effector was designed for harvesting lettuce. This design included a machine vision device, six photoelectric sensors and a fuzzy logic controller. The designed end effector was able to harvest lettuce at a rate of 5 s per lettuce with a success rate of 94.12%.

In an enclosed hygienic food gripper was designed with force feedback sensors. One finger on the gripper is stationary while the other finger moves by magnetic attraction. The actuator is placed inside with an inner magnet while an outer magnet moves the finger on the outside of the container

## FUTURE SCOPE OF ROBOTIC GRIPPERS:

The ability to grasp and hold objects is one of those human skills that robots have never quite got the hang of.

Most attempts to tackle the problem have centred around giving robots human-like fingers. That seems sensible, given that it's the solution discovered by the multibillion-year optimisation process we call evolution.

And yet, we clearly haven't yet uncovered all of nature's tricks. Robotic fingers generally require a centralised control system to handle data streams from touch and visual sensors and which then calculates how to carry out a grasping action.

Humans clearly have a way of short-cutting or simplifying this process. When was the last time you reached for a cup of coffee and had to think about how far apart your fingers should be or how hard you should grip?

Perhaps there's another way robots could do it, suggest Eric Brown at the University of Chicago and a few buddies. These guys have developed a robotic gripper capable of grabbing objects of almost any shape with an appropriate level of force but without any system of tactile or visual feedback.

The new device is deceptively simple. It consists of an airtight rubber bag filled with grains, in this case, of ground coffee, connected to a pump. The idea is to dump the bag on top of the object to be gripped so that the grains form loosely around it.

# Stamping Machine

- Shounak L, Rauf S, Avinash D, Ashutosh S

Stamping is a process used to impress a pattern or mark on a surface, object, or document using an engraved or inked block or die. Stamping machine is a machine which is used for marking of stamps on a desired surface. Eg: paper. The mechanism used for its working is scotch yoke mechanism.

## NEED:

- To perform stamping operation in least possible time, with precision.
- To reduce manual efforts.
- To make a machine which reduces manual efforts at low cost.

## DETAILS OF THE SYSTEM:

The device works on the principle of scotch yoke mechanism .

The material used for this project is wood and it has been joined at appropriate points by MS screws and rivets.

## WORKING:

The material to be stamped is kept on the table below the stamping mechanism. The crank of the scotch yoke mechanism is rotated with the help of a suitable motor. The stamp which is attached at the end of the link which is joined to the yoke, thus reciprocates vertically, and a stamp is marked on the desired surface.

## ADVANTAGES:

- Saves manual effort
- Portable
- Less floor space area required
- Less cost

## CONCLUSION:

The above device can be considered as a working skeleton model for future advancements like Making the working automatic by using microcontroller and sensors Thus with the above design and mechanism, we can fabricate a simple can crushing device

## APPLICATION:

Stamping mechanism is used in Newspaper publishing and Packaging industry. The mechanism can be automated.

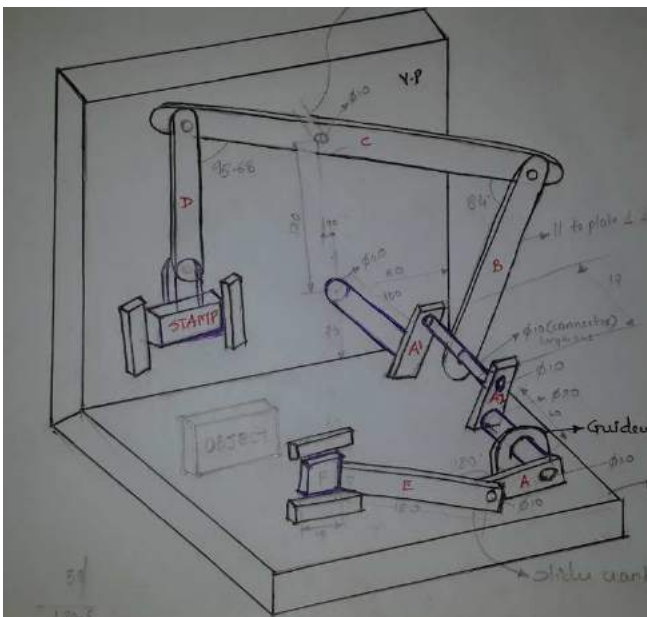



# Walking Mechanism

- Sudhir Y, Vijay Y, Chandan Y, Suraj V

## What is mechanism?

If a number of bodies are assembled in such a way that the motion of one cause constrained and predictable motion to the others, it is known as a mechanism.

Mechanism: the fundamental physical or chemical processes involved in or responsible for an action, reaction or other natural phenomenon.

Machine: an assemblage of parts that transmit forces, motion and energy in a predetermined manner.

Simple Machine: any of various elementary mechanisms having the elements of which all machines are composed. Included in this category are the lever, wheel and axle, pulley, inclined plane, wedge and the screw.

The word mechanism has many meanings. In kinematics, a mechanism is a means of transmitting, controlling, or constraining relative movement (Hunt 78). Movements which are electrically, magnetically, pneumatically operated are excluded from the concept of mechanism. The central theme for mechanisms is rigid bodies connected together by joints.

A machine is a combination of rigid or resistant bodies, formed and connected so that they move with definite relative motions and transmit force from the source of power to the resistance to be overcome. A machine has two functions:

transmitting definite relative motion and transmitting force. These functions require strength and rigidity to transmit the forces.

The term mechanism is applied to the combination of geometrical bodies which constitute a machine or part of a machine. A mechanism may therefore be defined as a combination of rigid or resistant bodies, formed and connected so that they move with definite relative motions with respect to one another

A leg mechanism(walking mechanism) is an assembly of links and joints(a linkage) intended to simulate the walking motion of humans or animals.

Mechanical legs can have one or more actuators, and can perform simple planar or complex motion

- Vertical speed as constant as possible while touching the ground
- While the foot is not touching the ground it should move as fast as possible
- Constant torque/force input
- The leg mechanism should allow forward and backward walking
- Minimized moving mass
- The foot has to touch the ground for at least half of the cycle for a two/four leg mechanism

## Application:

- Compared to a wheel, a leg mechanism is potentially better fitted to uneven terrain, as it can step over obstacles



Different types of walking mechanism



# Whitworth Quick Return Mechanism

- Aditya T, Ashutosh T, Snehal T, Siddharth T

## INTRODUCTION:

A quick return mechanism is an apparatus that converts circular motion (rotating motion following a circular path) into reciprocating motion (repetitive back-and-forth linear motion) in presses and shaping machines, which are utilized to shape stocks of metal into flat surfaces, throughout mechanical engineering. The quick return mechanism is the foundation behind the energy of these machines.

The mechanism consists of an arm attached to a rotating disc that moves at a controlled uniform speed. Unlike the crank, the arm of the mechanism runs at a different rate than the disc. By having the disc run at a different rate than the attached arm, productivity increases because the amount of time needed for a cut is reduced. The design of this mechanism specializes in vector calculus and the physical aspects of kinematics (study of motion without the effects of forces) and dynamics (study of forces that affect motion).

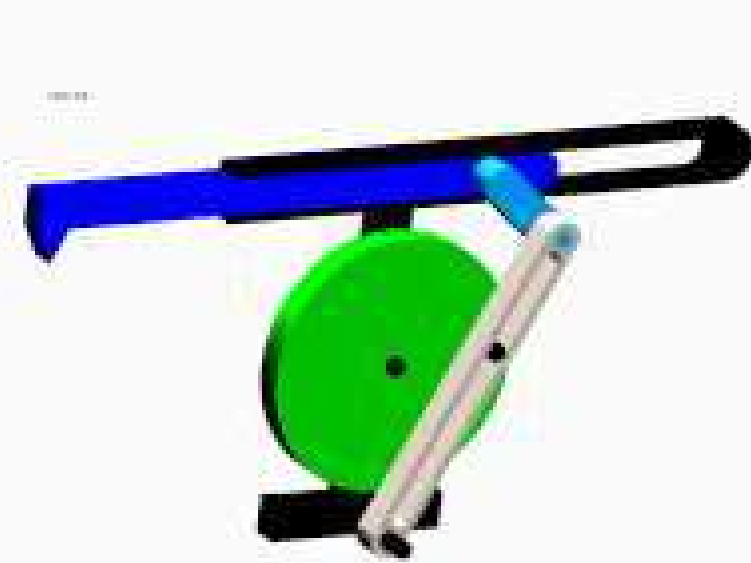

QUICK RETURN MECHANISM

## APPLICATIONS:

Many machine design applications have a need for difference in average velocity between the “forward” and “return” strokes. Typically some external work is being done by the linkage on the forward stroke, and the return stroke needs to be accomplished as rapidly as possible so that a maximum time will be available for the working stroke

Almost all reciprocating engines use cranks (with connecting rods) to transform the back-and-forth motion of the pistons into rotary motion. The cranks are incorporated into a crankshaft.

Quick return mechanisms are found throughout the engineering industry in different machines:

- Shaper Machine
- Rotary Engines
- Screw press
- Power-driven saw
- Mechanical actuator
- Revolver mechanisms
- Water pumping systems

## FUTURE SCOPE:

- Accurate instantaneous velocity measurement can be done by using precise instruments.
- Comparison can be made with Whitworth Quick Return Mechanism
- Vibration analysis can be performed.
- Model can be made to achieve higher quick return ratio.
- Kinematic and dynamic analysis can be performed.





Zephyr, our annual technical festival organised during month of September, it was a tremendous success. Approximately 6,000 participants and visitors contributed towards this festival which was held for 3 days.

The first day was highlighted by events like 'IC Racers', 'IC Jumble' and 'Project Exhibition'. The other events included a blend of technical and nontechnical events. Events like 'Treasure Hunt', 'Minute to win it', 'Rubix Cube' and 'Glow carrom' has a great response from participants. It was a social event conducted with the intent of raising awareness about environmental issues at the individual and local level.



# SOJOURN

Sojourn is a cultural fest where our engineering students are able to unveil their talent on the much isolated turf of performing arts. It is One Of The Most Eagerly Awaited College Activities Of The Year. It is an inspiration and dedication to the trends that made waves. Also setting a trend, the festival has ventured into the Inter-Collegiate arena.

The campus ablaze with enthusiasm exhibited by students in events like Fashion Show, Nach baliye, Drama, Laughter Challenge, Debates, GDs, and much more.





# JSW steel plant



**The flagship company of the over \$11 billion JSW Group, JSW Steel is testament to decades of experience and a dynamic culture that have culminated in the company becoming the leading manufacturer of value added and high end steel in India.**

The Group set up its first steel plant in 1982 at Vasind near Mumbai. Soon after, it acquired Piramal Steel Ltd., which operated a mini steel mill at Tarapur in Maharashtra. The Jindals, who had wide experience in the steel industry, renamed it as Jindal Iron and Steel Co. Ltd. (JISCO). Jindal Vijayanagar Steel Ltd. (JVSL) was set up in 1994, with its plant located at Toranagallu in the Bellary-Hospet area of Karnataka, the heart of the high-grade iron ore belt and spread over 3,700 acres (15 km<sup>2</sup>) of land. It is just 340 kilometres (210 mi) from Bangalore, and is well connected with both the Goa and Chennai Port. In 2005, JISCO and JVSL merged to form JSW Steel Ltd.

JSW Steel has also formed a joint venture for steel plant in Georgia. The Company has also tied up with JFE Steel Corp, Japan for manufacturing the high grade automotive steel. The Company has also acquired mining assets in Republic of Chile, United States and Mozambique.







As a part of the academic curriculum, the students of Mechanical Engineering, Thakur College of Engineering & Technology underwent an exciting industrial visit to JSW Steel Limited. They had an opportunity to personally interact with the staff and experience the operations live.





# Products

- Flat Products
- Hot Rolled (HR)
- Cold Rolled (CR)
- Color Coated Products
- JSW Pragati
- JSW Colouron
- JSW Colouron+
- Galvanised
- JSW Vishwas
- GALVECO
- Galvalume
- JSW Vishwas+
- GALVOS
- Long Products
- TMT Bars
- Neosteel Bars
- Wire Rods
- Special Alloy Steel



# ASME - CORE



(Vaibhav - Avinash - Saurabh - Venkatesh - Sumit - Nitin)

**VAIBHAV HAKKE**

Chairperson

**AVINASH GUPTA**

Vice Chairperson

**SAURABH VAIDYA**

Marketing Head

**VENKATESH MODI**

Treasurer

**SUMIT JHA**

Event Manager

**NITIN SINGH**

Secretary



---

# ACHIEVEMENTS

---

**Uddhav Karvir, Prasad Bagwe,  
Deepak Gupta, Omkar Bhogale and  
Niraj Chauhan.**

2nd in IIT Kanpur Techkriti IC RC Racing  
4th in IIT Bombay TechFest Full Throttle



---

# ACHIEVEMENTS

---

**Saurabh Vaidya & Deep Vira**

1st in Thadomal Sahani Engineering College

1st in L. R. Tiwari CoE

3rd in SPIT





---

# ACHIEVEMENTS

---

## Pratiksha Das

Part of India's first Women's Racing team

4th in Car drag race in Aamby valley Air Strip (India Speed Week)

5th in MRF National Bike Racing Championship



